



Technical Handbook

Systems and Solutions
for wastewater and
rainwater treatment



A close-up, low-angle shot of a person's feet stepping on a dark, wet rock in a stream. The person is wearing bright yellow pants and black sneakers with white laces. Water is splashing around the rock, creating a dynamic and energetic scene. The background is dark and out of focus, with some fallen leaves visible on the ground.

**we
make
life
flow**

Contents

The Roto Group.....	02
The company	03
Tools and services.....	04
Systems and solutions for civil and industrial wastewater / rainwater treatment.....	05

STANDARD INSTALLATIONS

Pre-treatment units.....	09
Grease trap Family 50.....	10 ÷ 11
Grease trap Family.....	12 ÷ 13
Grease trap Elliptic.....	14 ÷ 15
Grease trap Public.....	16 ÷ 17
Imhoff tank Bio Top HT.....	18 ÷ 19
Imhoff tank Bio Top Maxi.....	20 ÷ 21
Oil separators	22
Oil Separator Class 1.....	22 ÷ 23
Oil Separator Class 2.....	24 ÷ 25
Lifting stations	27
Pratica Family.....	28 ÷ 29
Pratica.....	30 ÷ 31
Pratica Roto.....	32 ÷ 33
Pratica Public.....	34 ÷ 35
Activated sludge systems.....	37
Super Plus.....	38 ÷ 39
Super Plus Mix.....	40 ÷ 41
Compact.....	42 ÷ 43
Poli 1.....	44 ÷ 45
Poli Maxi.....	46 ÷ 47
Percolating filter systems.....	48
Anapackage Type HT.....	48 ÷ 49
Anapackage.....	50 ÷ 51
Package.....	52 ÷ 53
Wastewater treatment units.....	55
Country.....	56 ÷ 57
Country Maxi.....	58 ÷ 59
Country Vertical Flow.....	60 ÷ 61
Water recovery.....	63
Eco Box.....	64 ÷ 65
Irriga Plus.....	66 ÷ 67
Irriga Plus Flat.....	68 ÷ 69
Storage for liquids.....	70
Tank – Horizontal cylindrical storage.....	70
Flat.....	70
Tank – R Horizontal cylindrical ribbed underground storage.....	71
Maxitank.....	71
Accessories	72
Static Screen.....	72
Splitter Box.....	73
Riser.....	73
Underground installation procedure	74

SPECIAL INSTALLATIONS

Field of study and realization	77
Activated sludge plants.....	78 ÷ 81
SBR reactors.....	82 ÷ 83
Fixed growth systems.....	84
Effluents from agro-food industries.....	85
Effluents from chemical and mechanical companies.....	86 ÷ 87

BIOFILTRATION SYSTEMS

Ecowash	88
Ecowash complete configuration.....	88 ÷ 93

Note: Pipes diameters of standard products may vary according to the working site requirements.

The ISEA brand story



In a rapidly changing world, with a growing population and a changing climate, water is key. Being one of the most precious resources on our planet, we today must radically change the way we use water. As a global industry leader that connects people with water and energy, ISEA is ready to take up this challenge and help shape a better tomorrow.

As one of the world's largest advanced plastic piping manufacturers, we combine the strength of a global group with the diversity and passion of our local teams. We offer world-class water and energy solutions across continents, and it is the specific knowledge and experience of our people on the field that makes the difference for our customers. Whether it is designing the most efficient water supply systems or meeting the ever-growing demands of cities and their inhabitants, we work closely together with our customers and partners to deliver trusted performance, today and tomorrow.

Our global network of leading local brands, intimate market understanding, and proven technical expertise means we are well placed to collaborate with our customers, so they can access the industry's most advanced products and services. We are constantly challenging ourselves to think further and faster, ensuring we deliver ever smarter, innovative and sustainable solutions that benefit people all over the world and that make life flow.

The production site in Puconci, SLO



Roto Group is an international company specialized in the production of plastic products. The roots of the family-run business go back to 1949. ROTO employs more than 600 people in 10 factories located in different European countries.

Roto generated revenues of €110 million in 2025, selling products in 70 countries around the world.

Roto is European leading rotomoulding company, producing more than 4,000 different products. The company's development is ensured by continuous innovation, new technologies and materials that ROTO develops together with scientific institutes, universities and other companies.

The Roto-branded product groups are divided into four segments: products for agriculture, garden, sport and ecology. The use of composites and biodegradable and recycled polymers enables the production of the most complex products on the market.

Roto also manufactures a wide range of components products for various industries such as automotive, marine, construction and agricultural machinery, aquaculture and logistics. Added value innovative design, the use of intelligent polymers and composites, upgrade of products with accessories.

Tools and services

For sustainable wastewater management



Training

ISEA shares the experience of over 50 years of practice with hydraulics professionals, integrating the product portfolio with a specific and permanent offer of trainings.

We organise courses introducing ISEA products both at our own premises and at the customer's site.

ISEA engineering solutions for wastewater treatment

Our Technical Department offers to professionals a "turnkey" solution, taking care of the project, materials, assembly and testing procedures. ISEA develops custom solutions, first by meeting the customer, holding on-site inspections and working with the technical staff in order to define how to meet the customer's needs.

Strengths

- Preliminary site inspections
- Project-appropriate choices
- A-to-Z service
- "Turnkey" delivery

Compliance with standards

The treatment of domestic, commercial or industrial wastewater has grown into an issue of paramount importance, both in terms of protecting people and the environment they inhabit and in terms of ever-stricter limits of acceptability of the relevant regulatory framework. ISEA provides a total assistance since the first approach to the problem up to the final solution satisfying at the most customer's needs.

www.roto-ISEA.it

Our website is constantly updated and it contains information about the most recent products and solutions. It enables viewers to reach technical data concerning our products in a fast and comfortable way by downloading them on their computers.



ISEA systems and solutions

For civil and industrial wastewater / rainwater treatment



For more than 25 years now ISEA has been offering its engineering solutions to the market, specializing in wastewater treatment starting from the concept through manufacturing and installation, up to maintenance. The site is located in the industrial zone of Nord Italy.

The complex includes:

- **engineering office;**
- **assembly plant;**
- **logistic centre;**
- **technical services;**
- **administration services.**

Initially specialised in 5-25 EI and 25-100 EI modules, the company has been constantly widening its portfolio to reach the variety of market needs and, particularly, to perform on petrol installations and built up areas to 3000 EI.

Thanks to its experience, ISEA developed two types of highly efficient installations, for effluents treatment based on of activated sludge system.

- Standard modules of rotomoulded polyethylene for isolated houses and small residential areas (up to 300 EI) show up in the first part of the catalogue (standard products)
- Tailor made installations, for wastewater treatment for medium size built up areas (from 300 to 3000 EI) that are show up in the second part of the catalogue (special installations).

A new graphic cutline ISEA offers key points for a faster and more effective overview of all the ISEA range, divided into several modules:

PRODUCT DESCRIPTION: containing product specification and description.

INSTALLATION: providing indications and graphic support to simplify and optimise the assembly and implementation of the product

USE: setting up, monitoring and maintaining the installations.





Wastewater treatment units



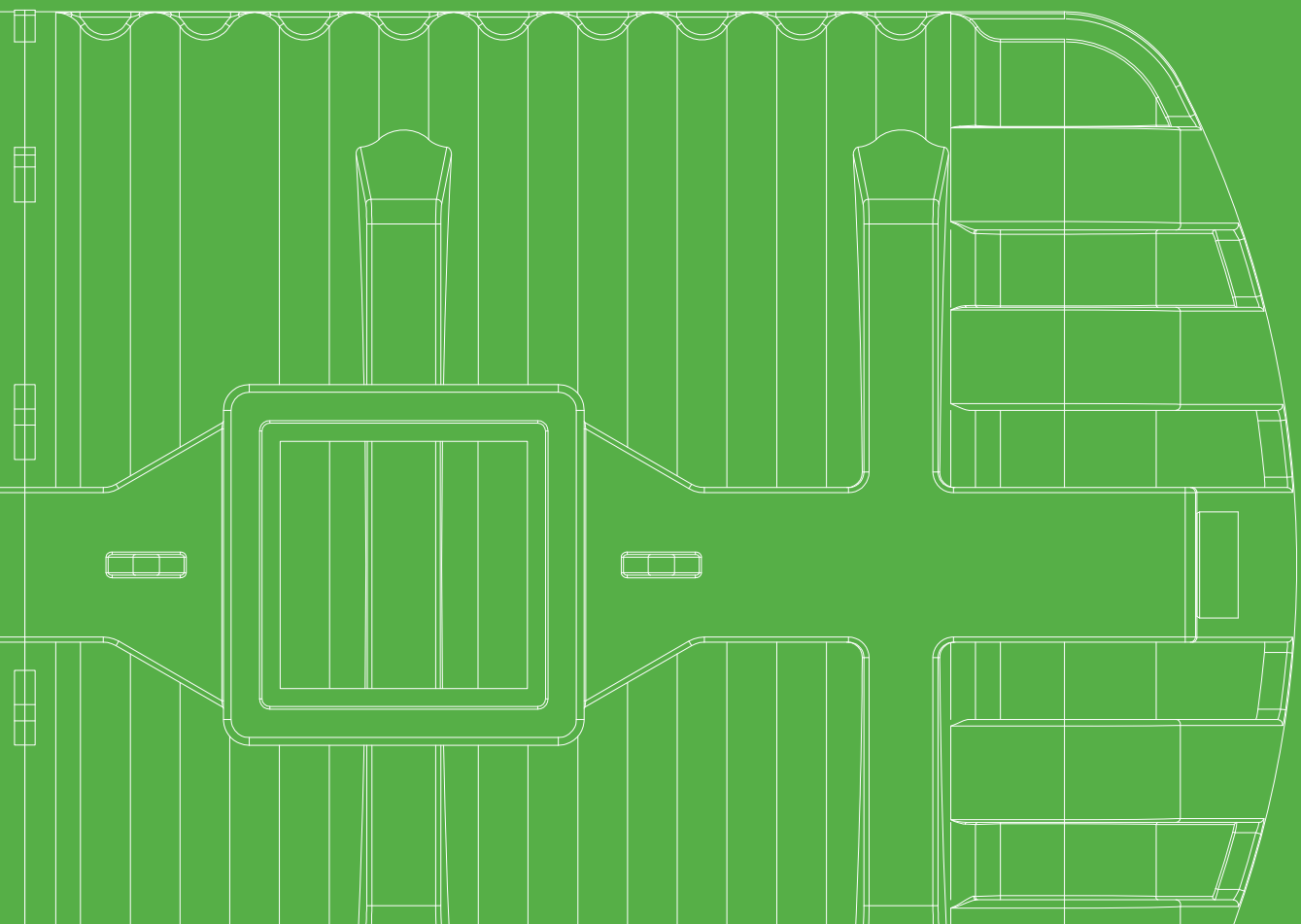
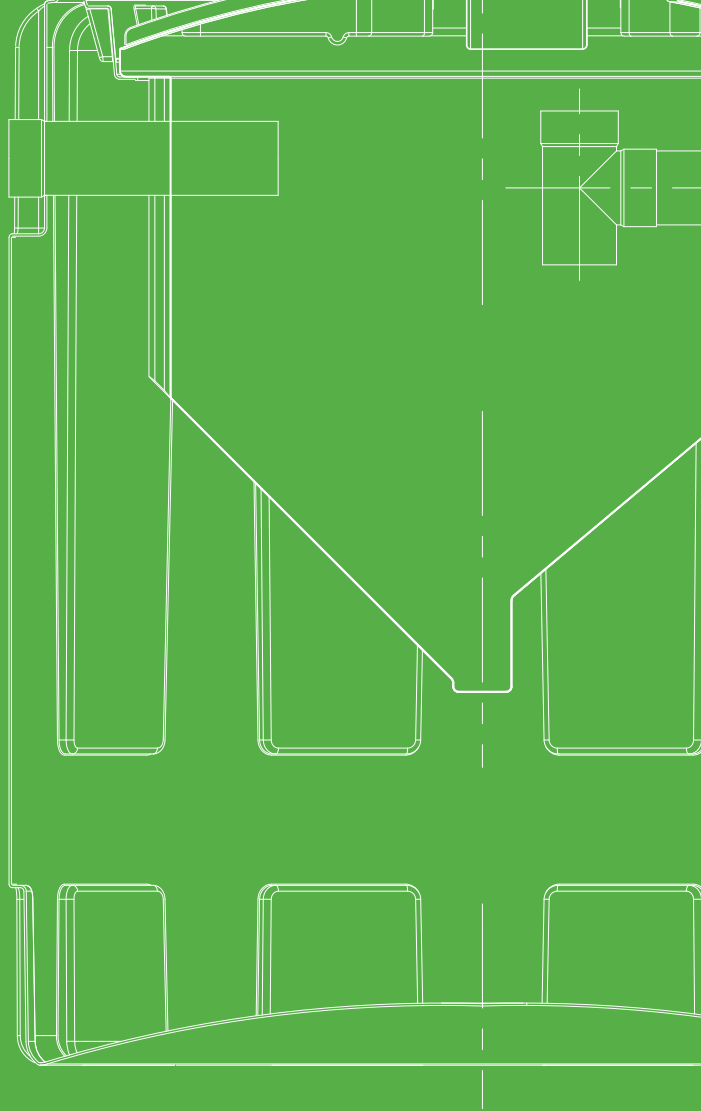
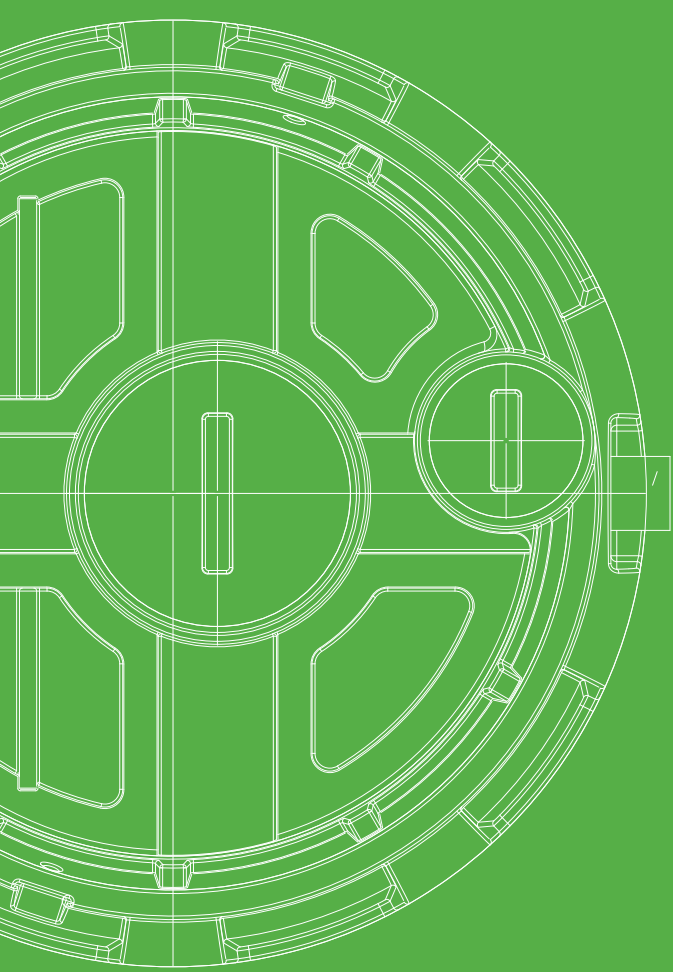

Pre-treatment units



Grease traps are used for the pre-treatment of civil grey water (from kitchens, washing machines, washbasins, showers, etc.), before it is conveyed into the public sewer or upstream from a suitable treatment plant (activated sludge, sub irrigation, percolating filter plant, etc.).

Grease is separated by means of a physical process of removing all substances whose specific weight is lower than the wastewater's, i.e. the kind of substances typically found in wastewater produced by kitchens, restaurants or canteens.

Separation of sand and inert matter is also a physical process, but consists on evacuation of all the substances whose specific weight is higher than water's.

Grease needs to be removed as it can have serious harmful consequences during the course of subsequent treatment, such as during the aerobic biological process, anaerobic digestion, settling or lifting.

Imhoff septic tanks are commonly used for the pre-treatment of domestic and commercial sewage (from toilets), before it is conveyed into the public sewer or upstream from a suitable treatment plant.

The faecal material is separated by means of a physical process of decanting all substances whose specific weight is higher than the wastewater's.

This process is very important, as it helps to improve wastewater quality before it is conveyed to the proper sanitation treatment.

GREASE TRAP FAMILY 50

Under sink pre-treatment unit



PRODUCT CATEGORY

Grease trap

PRODUCT NAME

FAMILY GREASE TRAP 50

APPLICATION

Pre-treatment of wastewater from kitchens

SIZE

0,1 l/sec

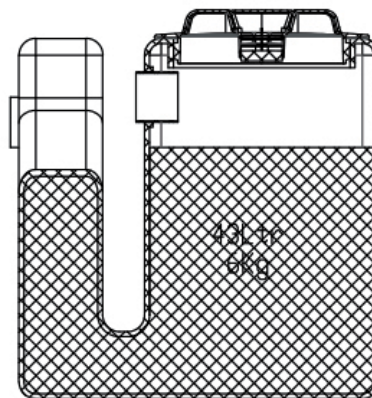
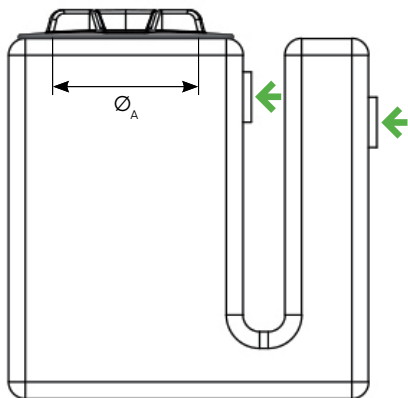
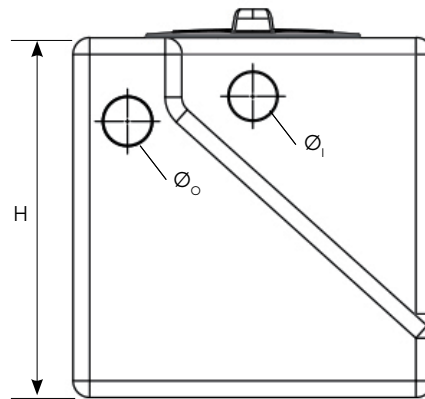
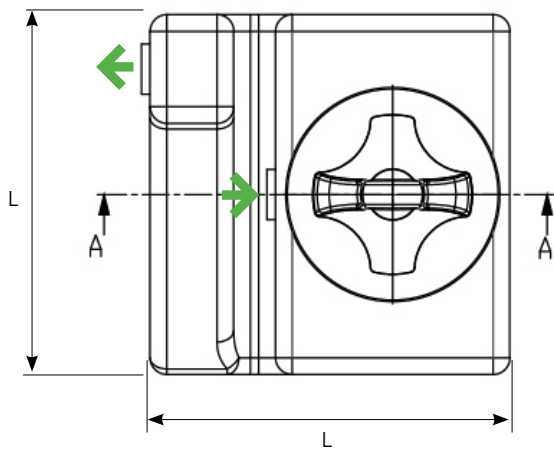

Item	Code	Size (l/s)	Capacity (l)	LxL (cm)	H (cm)	$\phi_1 - \phi_0$ (mm)	ϕ_A (cm)
DEG.FAMILY 50	IS00510	0,1	48	43x43	43	40/50	16,5

PRODUCT DESCRIPTION

Polyethylene Grease Trap, single-block, to be installed in tight

spaces, e.g. under the sink, to limit the polluting load when channeled to either a public sewer or a private treatment plant.

Designed to obtain an efficient grease separation and a good

hydraulic flow, it is suitable to be used when the

installation of a standard grease trap underground is not possible.

The Grease Trap is equipped with a threaded cover for full inspection and easy removal of grease and other floating materials.

The product is completely made of recyclable materials.

COMPLIANCE WITH STANDARD

UNI EN 1825

HOW TO INSTALL EXAMPLE

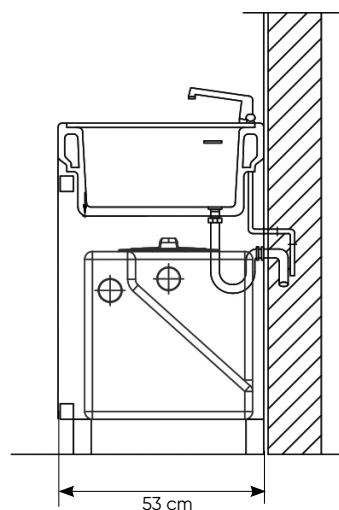
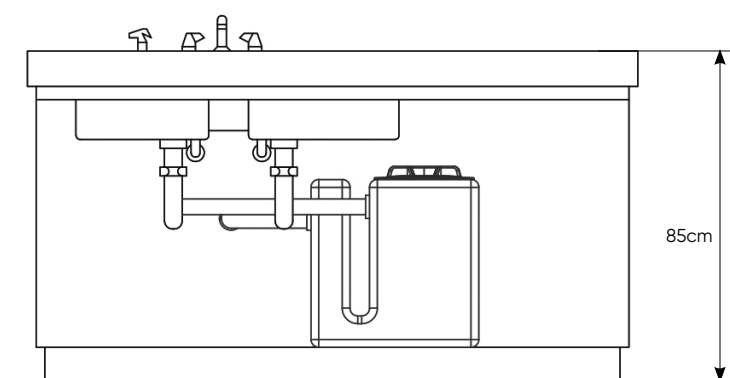

Provided with a set of seals for multiple diameter connections, 3 x inlet:
 Ø 1"1/4 (32mm)
 Ø 1"1/2 (40mm)
 Ø 2" (50mm)

1 x OUT (outlet)

New compact design

Easy to install

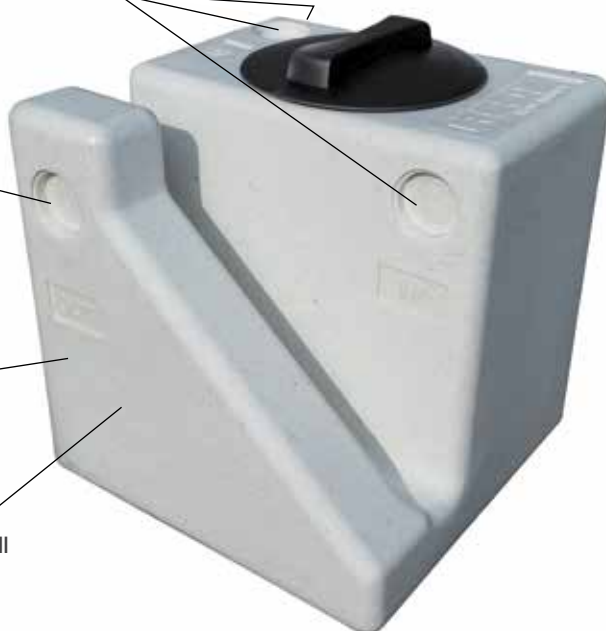

Easy cleaning access



GREASE TRAP FAMILY

Pre-treatment solutions



PRODUCT CATEGORY

Grease trap

PRODUCT NAME

FAMILY GREASE TRAP

APPLICATION

Pre-treatment of wastewater from kitchens and washing machines

SIZE

0,4 - 8 l/sec

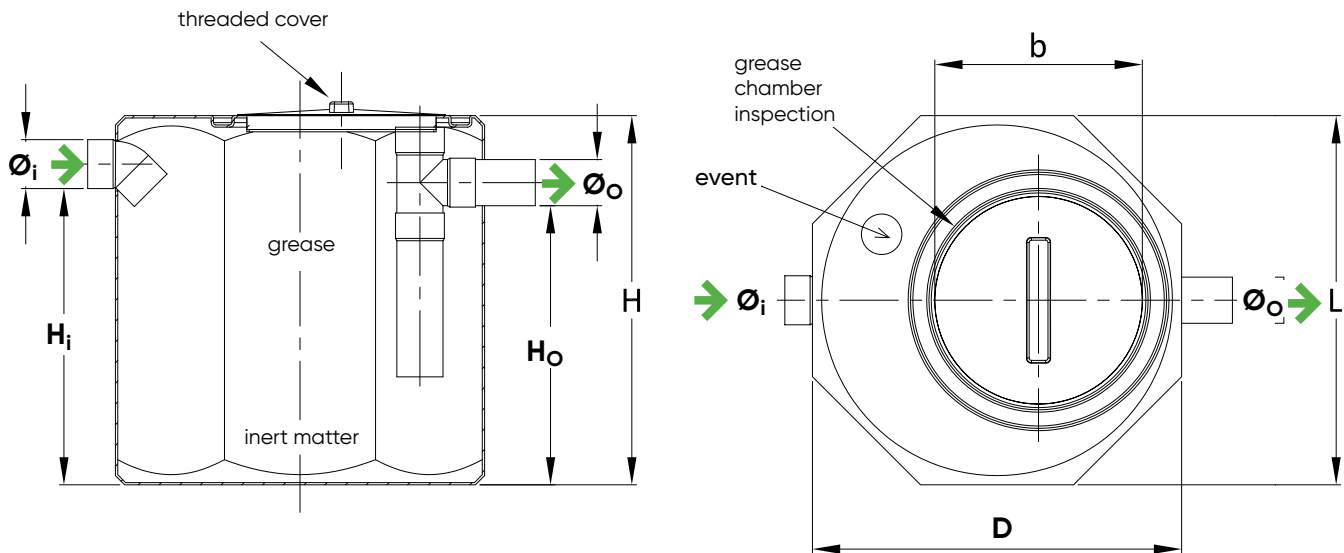

Item	Code	Size (l/s)	Meals per day	Capacity (l)	D (cm)	H (cm)	Hi (cm)	Ho (cm)	Øi and Øo (mm)	b (cm)
DEG. FAMILY 250	IS00514	0,4	-	169	60x68	82	63	60	100	20
DEG. FAMILY 350	IS00515	0,6	-	229	60x68	100	84	81	100	20
DEG. FAMILY 400	IS05111	1	-	285	80	80	63	56	100	40
DEG. FAMILY 800	IS05112	1	-	475	80	120	103	96	100	40
DEG. FAMILY 1200	IS05113	3	150	1.038	120	120	102	95	100	30
DEG. FAMILY 1600	IS05114	4	200	1.549	120	160	142	135	125	30
DEG. TOP 2000	IS05115	5	300	1.884	120	200	180	173	140	30
DEG. TOP 3000	IS05116	6	400	2.560	160	160	138	132	140	40
DEG. TOP 4000	IS05117	7	600	3.273	160	200	176	169	160	40
DEG. TOP 5000	IS05118	8	800	4.035	160	240	215	208	160	40

Accessory Code

Grease level alarm kit ISSEN14

PRODUCT DESCRIPTION

One-piece polyethylene Grease Trap Family, size 1 to 13, complete with screw-on cover for central and lateral inspection, removing grease, floating material, sand and inert matter. Featuring PVC inlet pipe section, PVC treated water outlet pipe section with external neoprene seal, outlet T fitting (or 90° elbow fitting) and inspection cap; for application on kitchen and canteen drain lines: Grease Trap Family is produced with recyclable material.

INSTALLATION (p. 74)

PIT

Dig a suitably sized pit. Line the bottom of the pit with a 10 cm thick layer of sand or other aggregate with a particle size ranging from 0 to 5 mm. Dampen the sand and level the surface on which the Grease Trap Family will sit.

CONNECTIONS

Connect the outlet of Grease Trap Family with downstream system elements using a relevant PVC pipe. Connect the inlet with suitable piping.

FILLING

Fill the Grease Trap Family with water in order to start the biological process properly.

BACKFILLING AND FINISHING

Backfill around the sides with damp sand or other aggregate with a particle size ranging from 0 to 5 mm. If necessary, build a 5 cm layer on the top of the pit using light cement or produce a concrete slab at least 25 cm thick in case of vehicular traffic.

USE

CHECKING AND MAINTENANCE

Make sure that installation is carried out as prescribed in a professional manner. Check at regular intervals to make sure no coarse matter is blocking the wastewater inlet or treated water outlet through the openings in the top fitted with screw-on covers. At regular intervals, open the screw-on cover to make sure that settled sand is not blocking the outlet pipe.

At least once a month, make sure that the grease level does not rise above the base of the outlet pipe. Remove floating grease regularly, calling a specialised company.

OPTIONAL

Grease level alarm system.

COMPLIANCE WITH STANDARD

CE - UNI EN 1825



GREASE TRAP ELLIPTIC

Pre-treatment units

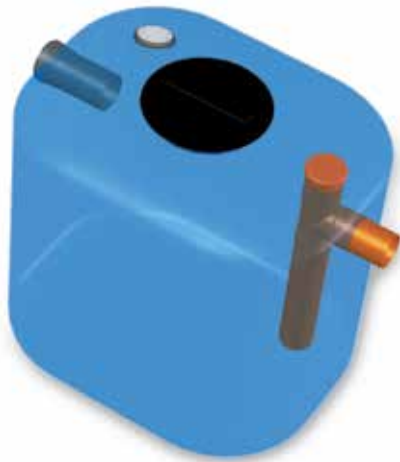

PRODUCT CATEGORY

Grease trap

PRODUCT NAME

PC GREASE TRAP

APPLICATION

Pre-treatment of wastewater from kitchens and washing machines.

SIZE

1 - 2 l/sec

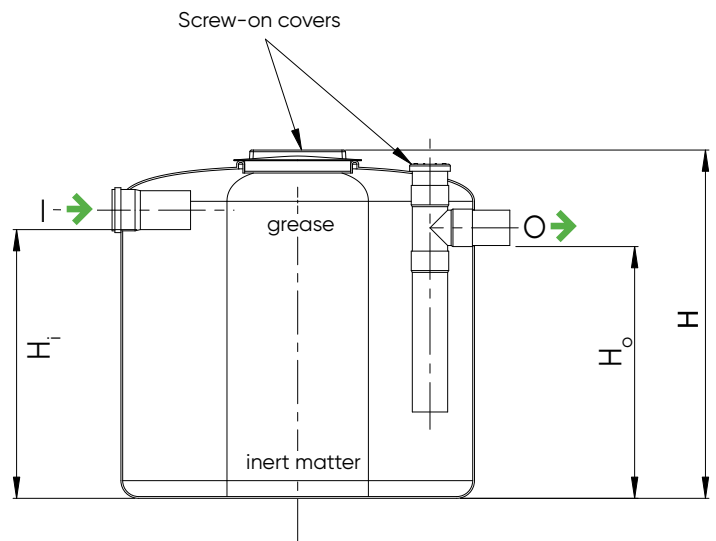
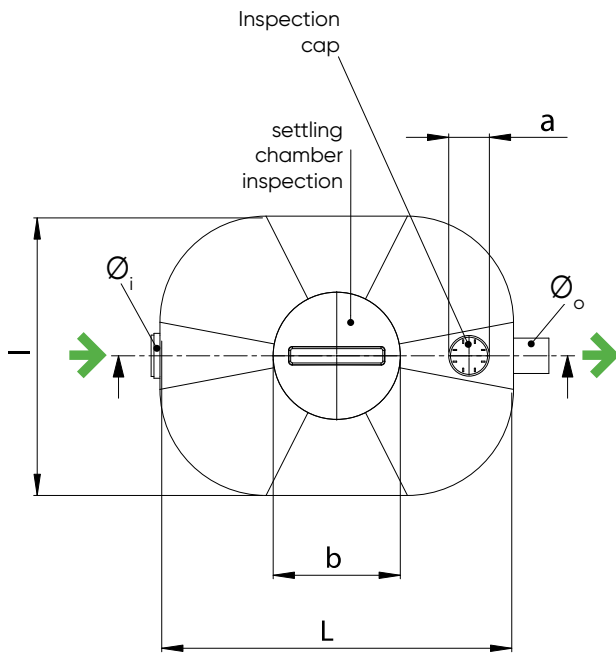

Item	Code	Size (l/s)	Meals per day	Capacity (l)	lxL (cm)	H (cm)	a (cm)	b (cm)	H _i (cm)	H _U (cm)	Ø _i and Ø _o (mm)
DEG. PC A1	IS00511	1	50	417	78x100	95	100	300	74	70	100
DEG. PC A2	IS00512	2	100	800	78x128	123	100	300	105	101	100

Accessory

Code

Grease level alarm kit ISSEN14

PRODUCT DESCRIPTION

PC Grease Trap, size 1-2; featuring one piece elliptical shaped construction made from polyethylene, complete with screw-on cover both for central inspection and removing grease and floating material, and for side inspection and removing sand and inert matter. Featuring PVC or PP inlet pipe section; PVC treated water outlet pipe section with external neoprene seal, outlet T fitting (or 90° elbow fitting) and inspection cap; for application on kitchen and canteen drain lines; produced with fully recyclable material.

INSTALLATION (p. 74)

PIT

Dig a suitably sized pit. Line the bottom of the pit with a 10 cm thick layer of sand or other aggregate with a particle size ranging from 0 to 5 mm. Dampen the sand and level the surface on which the PC Grease Trap will sit.

CONNECTIONS

Connect the outlet of PC Grease Trap with downstream system elements using a relevant PVC pipe. Connect the wastewater pipes to the PC Grease Trap inlet to start the treatment process.

FILLING

Fill the PC Grease Trap with water in order to start the biological process properly.

BACKFILLING AND FINISHING

Backfill around the sides with damp sand or other aggregate with a particle size ranging from 0 to 5 mm. If necessary, build a 5 cm layer on the top of the pit using light cement or produce a concrete slab at least 25 cm thick in case of vehicular traffic.

USE

CHECKING AND MAINTENANCE

Make sure that installation is carried out as prescribed in a professional manner. Check at regular intervals to make sure no coarse matter is blocking the wastewater inlet or treated water outlet through the openings in the top fitted with screw on covers. At regular intervals, open the screw on cover to make sure that settled sand is not blocking the outlet pipe.

At least once a month, make sure that the grease level does not rise above the base of the outlet pipe. Remove floating grease regularly, calling a specialised company.

OPTIONAL

Grease level alarm system.

COMPLIANCE WITH STANDARD

UNI EN 1825

GREASE TRAP PUBLIC

Pre-treatment units



PRODUCT CATEGORY

Grease trap public

PRODUCT NAME

PUBLIC GREASE TRAP

APPLICATION

Pre-treatment of wastewater from kitchens and canteens

SIZE

10 - 14 l/sec

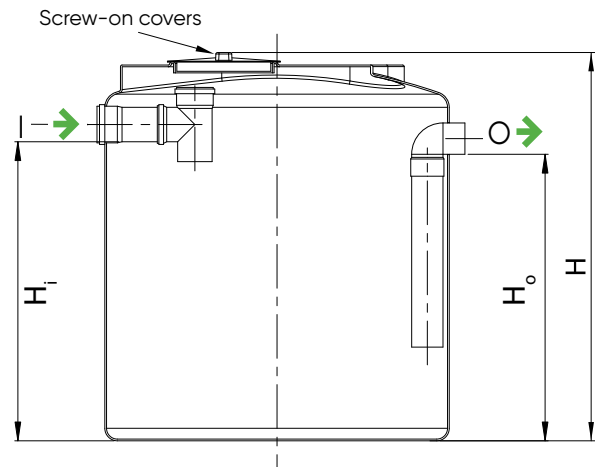
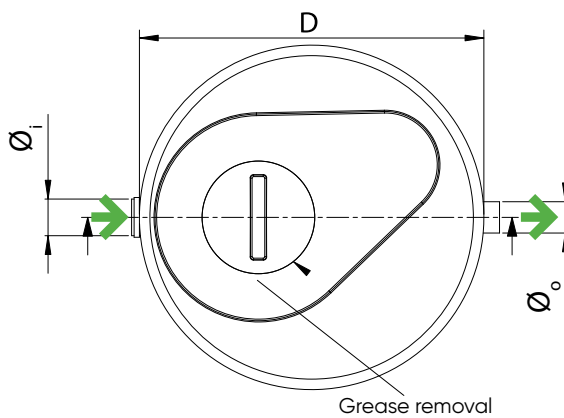

Item	Code	Size (l/s)	Meals per day	Capacity (l)	lxL or D (cm)	H (cm)	H _i (cm)	H _o (cm)	Ø _i and Ø _o (mm)	b (cm)
DEG. PUBLIC 6000	IS00416	10	1.000	6.096	215	220	173	166	200	60
DEG. PUBLIC 8000	IS00417	12	1.100	7.693	215	275	221	214	200	60
DEG. PUBLIC 10000	IS00418	14	1.400	8.350	215	310	250	243	200	60

Accessory

Code

Grease level alarm kit	ISSEN14
------------------------	---------

PRODUCT DESCRIPTION

One-piece polyethylene Grease Trap Public, size 10-14, complete with screw-on cover both for central inspection and removing grease and floating material, and for removing sand and inert matter. Featuring PVC inlet pipe section; PVC treated water outlet pipe section with external neoprene seal, outlet tee fitting and inspection cap; for application on kitchen and canteen drain lines. Produced with recyclable material.

INSTALLATION (p. 74)

PIT

Dig a suitably sized pit. Line the bottom of the pit with a 10 cm thick layer of sand or other aggregate with a particle size ranging from 0 to 5 mm. Dampen the sand and level the surface on which the Grease Trap Public will sit.

CONNECTIONS

Connect the outlet of Grease Trap Public with downstream system elements using a relevant PVC pipe. Connect the wastewater pipes to the Grease Trap Public inlet using suitable fittings to start the treatment process.

FILLING

Fill the Grease Trap Public with water in order to start the biological process properly.

BACKFILLING AND FINISHING

Backfill around the sides with damp sand or other aggregate with a particle size ranging from 0 to 5 mm. If necessary, build a 5 cm layer on the top of the pit using light cement or produce a concrete slab at least 25 cm thick in case of vehicular traffic.

USE

CHECKING AND MAINTENANCE

Make sure that installation is carried out as prescribed in a professional manner. Check at regular intervals to make sure no coarse matter is blocking the wastewater inlet or treated water outlet through the openings in the top fitted with screw on covers. At regular intervals, open the screw-on cover to make sure that settled sand is not blocking the outlet pipe. At least once a month, make sure that the grease level does not rise above the base of the outlet pipe. Remove floating grease regularly, calling a specialised company. To improve the unit's treatment efficiency and reduce the amount of maintenance required, a dose of grease digesting bacterial solution can be added inside.

OPTIONAL

Grease level alarm system.

COMPLIANCE WITH STANDARD

CE - UNI EN 1825



BIO TOP HT

Pre-treatment units



PRODUCT CATEGORY

IMHOFF TANK

PRODUCT NAME

BIO TOP HT

APPLICATION

Treatment of domestic and commercial wastewater

NO. OF USERS SERVED

5 – 50 E.I.

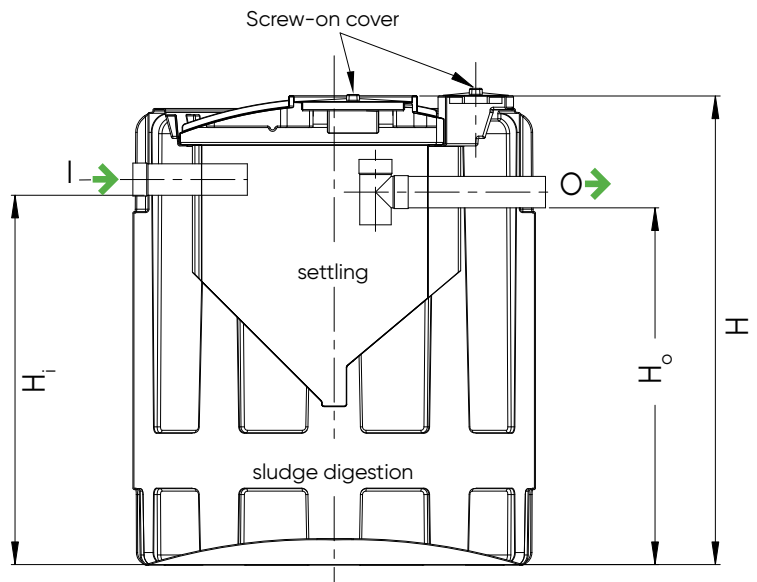
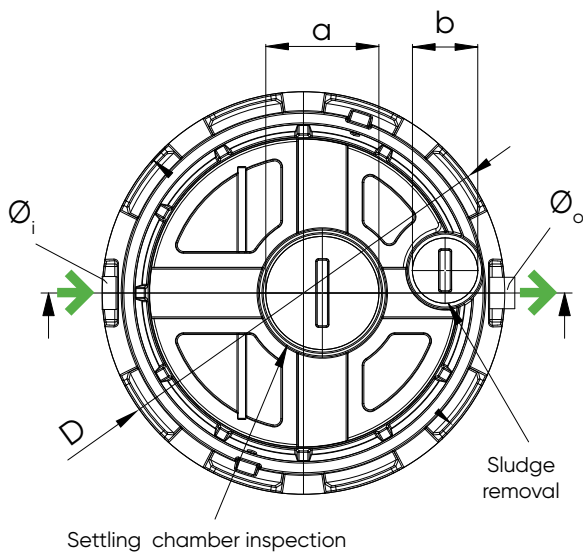

Item	Code	Users (E.I.)	Capacity (l)	D (cm)	H (cm)	a (cm)	b (cm)	V sett (m ³)	V dig (m ³)	Hi (cm)	Ho (cm)	Øi and Øo (mm)
BIO FAMILY HT 1000	IS103HT	5	1.100	120	120	40	-	0,24	0,86	100	97	100
BIO FAMILY HT 1500	IS104HT	7	1.500	120	150	40	-	0,4	1,1	125	122	125
BIO FAMILY HT 2000	IS105HT	10	2.100	120	190	40	-	0,6	1,5	165	162	125
BIO TOP HT 3000	IS170HT	15	2.800	160	185	40	20	0,8	2,0	147	144	125
BIO TOP HT 4000	IS171HT	20	3.800	160	235	40	20	1,2	3,0	197	194	140
BIO TOP HT 5000	IS172HT	25	4.874	190	215	40	20	1,6	4,0	177	174	140
BIO TOP HT 6000	IS173HT	30	6.000	190	255	40	20	2,0	5,0	217	214	140
BIO TOP HT 8000	IS174HT	40	7.598	220	260	20	40	2,6	6,5	211	208	160
BIO TOP HT 9000	IS175HT	45	8.738	220	285	20	40	3,0	7,5	236	233	160
BIO TOP HT 10000	IS176HT	50	9.498	220	310	20	40	3,4	8,5	261	258	160

PRODUCT DESCRIPTION

What differentiates Imhoff tanks from septic tanks is the presence of two clearly separate processes of settling and digestion of the sludge. Imhoff Bio Top HT tanks are made by polyethylene with ribbed structure. Bio Top HT tank is featured with 2 compartments (settling chamber and a sludge digestion chamber), forming a one piece construction.

DIMENSION PARAMETERS

In the settling part, the volume is based on the lasting time, which at the lower limit equals 1h 30 min at the peak flow.

The surface of the settle tank in square meters has to equal to the value of peak flow.

The dimension of digestion tank is 1,5 times of the daily effluent volume, which corresponds to a volume of closely 150 l per user. The total volume of Bio Top HT tank is in general about 200 l per user.

OPERATION PARAMETERS

The interior chamber of Bio Top HT tank is situated in the upper part and its task is to separate all the suspended solids from the liquids through a settling process. The trapped matter falls then into the digestion chamber through the connection pipe. Organic substances undergo anaerobic fermentation, which leads to their liquefaction and as a result the mineralization of the sludge. The digestion efficacy depends on the temperature. For example, with the temperature of 20°C the half of organic matter, i.e. 40% of total mass of the sludge is mineralized. The tank is featured with two inspection covers in both settling and digestion compartments.

The Bio Top HT tank is also fitted with inlet and outlet pipes, PVC treated fittings with external neoprene seal.

INSTALLATION (p. 74)

CONNECTIONS

Connect the outlet to an inspection chamber with a PVC pipe. Connect the wastewater pipes to the unit inlet in order to start the treatment process.

FILLING

Fill the unit with clean water to start the separation process properly.

BACKFILLING AND FINISHING

Dig a pit leaving a space of about 20 cm around the unit. Line the bottom of the pit with concrete dosed 150 kg per a 10 cm thick layer. Connect the Bio Top HT Imhoff tank outlet to an inspection chamber with a PVC pipe. Connect the inlet with suitable piping. Fill the HT Imhoff tank with water to start the biological process properly. Top the backfill as directed in the technical sheet or on stickers applied to all our devices.

MAINTENANCE

Make sure that installation is carried out as prescribed in a professional manner. Check at regular intervals to make sure no coarse matter is blocking the sewage inlet or treated water outlet. At regular intervals, make sure that the sludge level in the digestion compartment does not rise above the bottom of the settling chamber. At least once a year have part of the sludge contained in the digester removed, using the smaller opening fitted with the screw on cover, calling a specialized company.

ADVANTAGES OF PLACING IMHOFF TANK UPSTREAM FROM ACTIVATED SLUDGE SYSTEM

In order to lighten the pollutant loading, arriving to the activated sludge systems (e.g. gamma POLI), it can be beneficial to place an Imhoff tank upstream. Indeed, in the settling chamber of Imhoff tank, suspended matter decreases of up to 55%, and the DBO5 of about 25%.

Thanks to reducing the DBO5 loading, we can choose an aeration chamber with lower volume.

Furthermore, suspended solids trapped in the settling chamber fall into the digestion compartment, composing the primary sludge. The same compartment contains also the secondary sludge, coming from the biological treatment.

Thus, the Imhoff tank plays also a role of a storage compartment, successfully replacing storage tanks.

TREATMENT PERFORMANCE

DBOS reduction = 40%

MLSS reduction = 60%

COMPLIANCE WITH STANDARD

91/27/CE

BIO TOP MAXI
Pre-treatment units



PRODUCT CATEGORY

IMHOFF tank

PRODUCT NAME

BIO TOP MAXI

APPLICATION

Pre-treatment of urban effluents

NO. OF USERS SERVED

80 - 200 E.I.

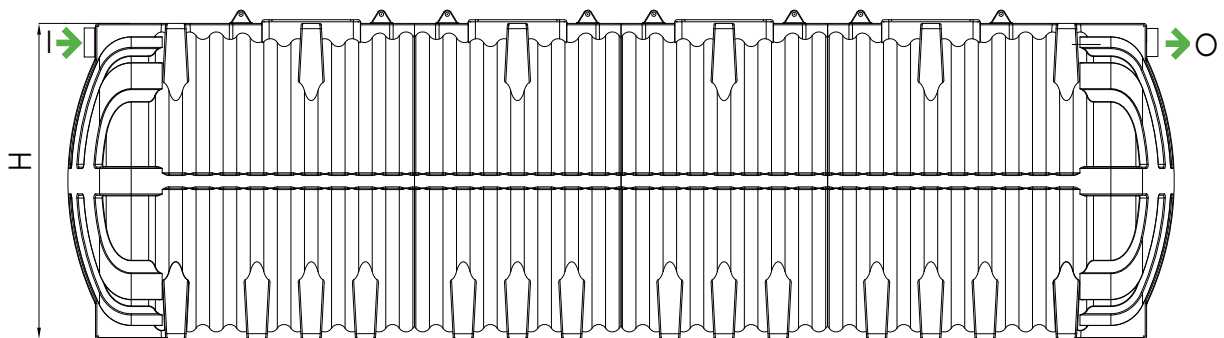
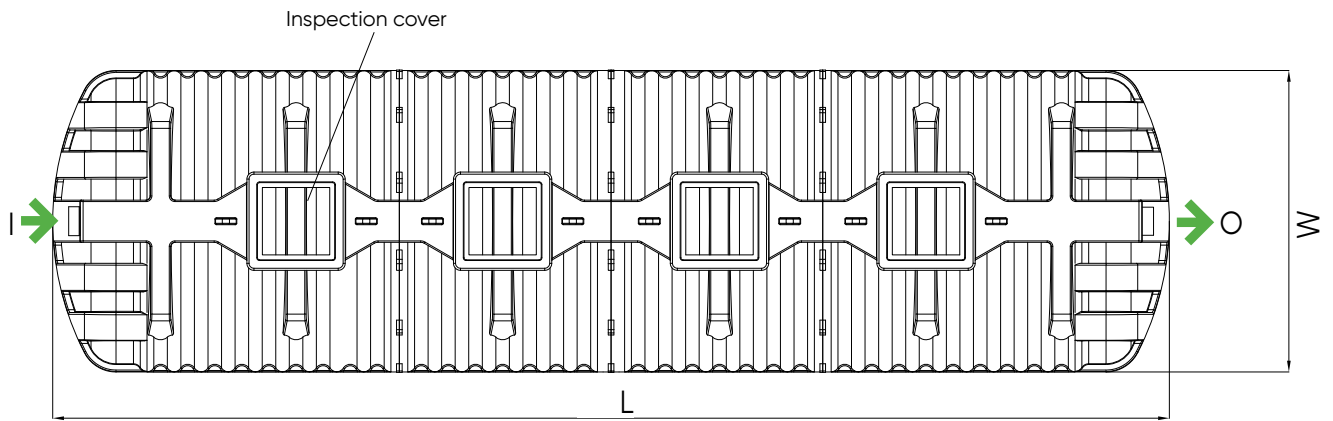

Item	Code	Users (E.I.)	W (cm)	L (cm)	H (cm)	Inspection cover 500x500 mm (n°)
BIO MAXI 16000	IS00700	80	214	494	228	2
BIO MAXI 21000	IS00701	100	214	646	228	3
BIO MAXI 26000	IS00702	130	214	798	228	4
BIO MAXI 31000	IS00703	150	214	950	228	5
BIO MAXI 36000	IS00704	180	214	1102	228	6
BIO MAXI 41000	IS00705	200	214	1254	228	7

PRODUCT DESCRIPTION

What differentiates Imhoff tanks from septic tanks is the presence of two clearly separate processes of settling and digestion of the sludge. Imhoff Bio Top Maxi tanks are made by polyethylene with ribbed structure. Bio Top Maxi tank is featured with 2 compartments (settling chamber and a sludge digestion chamber), forming a one piece construction.

DIMENSION PARAMETERS

In the settling part, the volume is based on the lasting time, which at the lower limit equals 1h 30 min at the peak flow.

The surface of the settle tank in square meters has to equal to the value of peak flow.

The dimension of digestion tank is 1,5 times of the daily effluent volume, which corresponds to a volume of closely 150 l per user. The total volume of Bio Top HT tank is in general about 200 l per user.

OPERATION PARAMETERS

The interior chamber of Bio Top Maxi tank is situated in the upper part and its task is to separate all the suspended solids from the liquids through a settling process. The trapped matter falls then into the digestion chamber through the connection pipe. Organic substances undergo anaerobic fermentation, which leads to their liquefaction and as a result the mineralization of the sludge. The digestion efficacy depends on the temperature. For example, with the temperature of 20°C the half of organic matter, i.e. 40% of total mass of the sludge is mineralized. The tank is featured with two inspection covers in both settling and digestion compartments.

The Bio Top HT tank is also fitted with inlet and outlet pipes, PVC treated fittings with external neoprene seal.

INSTALLATION (p. 74)

CONNECTIONS

Connect the outlet to an inspection chamber with a PVC pipe. Connect the wastewater pipes to the unit inlet in order to start the treatment process.

FILLING

Fill the unit with clean water to start the separation process properly.

BACKFILLING AND FINISHING

Dig a pit leaving a space of about 20 cm around the unit. Line the bottom of the pit with concrete dosed 150 kg per a 10 cm thick layer. Connect the Bio Top Maxi Imhoff tank outlet to an inspection chamber with a PVC pipe. Connect the inlet with suitable piping. Fill

the HT Imhoff tank with water to start the biological process properly. Top the backfill as directed in the technical sheet or on stickers applied to all our devices.

MAINTENANCE

Make sure that installation is carried out as prescribed in a professional manner. Check at regular intervals to make sure no coarse matter is blocking the sewage inlet or treated water outlet. At regular intervals, make sure that the sludge level in the digestion compartment does not rise above the bottom of the settling chamber. At least once a year have part of the sludge contained in the digester removed, using the smaller opening fitted with the screw on cover, calling a specialized company.

ADVANTAGES OF PLACING IMHOFF TANK UPSTREAM FROM ACTIVATED SLUDGE SYSTEM

In order to lighten the pollutant loading, arriving to the activated sludge systems (e.g. gamma POLI), it can be beneficial to place an Imhoff tank upstream. Indeed, in the settling chamber of Imhoff tank, suspended matter decreases of up to 55%, and the DBO5 of about 25%. Thanks to reducing the DBO5 loading, we can choose an aeration chamber with lower volume. Furthermore, suspended solids trapped in the settling chamber fall into the digestion compartment, composing the primary sludge. The same compartment contains also the secondary sludge, coming from the biological treatment. Thus, the Imhoff tank plays also a role of a storage compartment, successfully replacing storage tanks.

TREATMENT PERFORMANCE

DBOS reduction = 40%

MLSS reduction = 60%

COMPLIANCE WITH STANDARD 91/27/CE



OTTO PE
Oil and hydrocarbon separator class 1

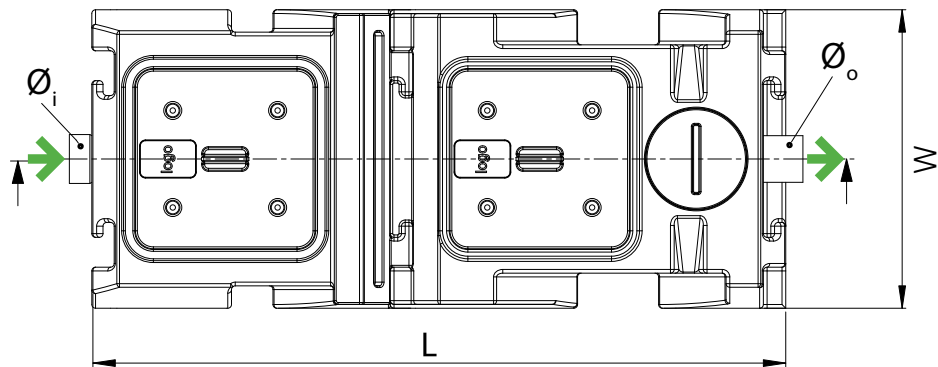
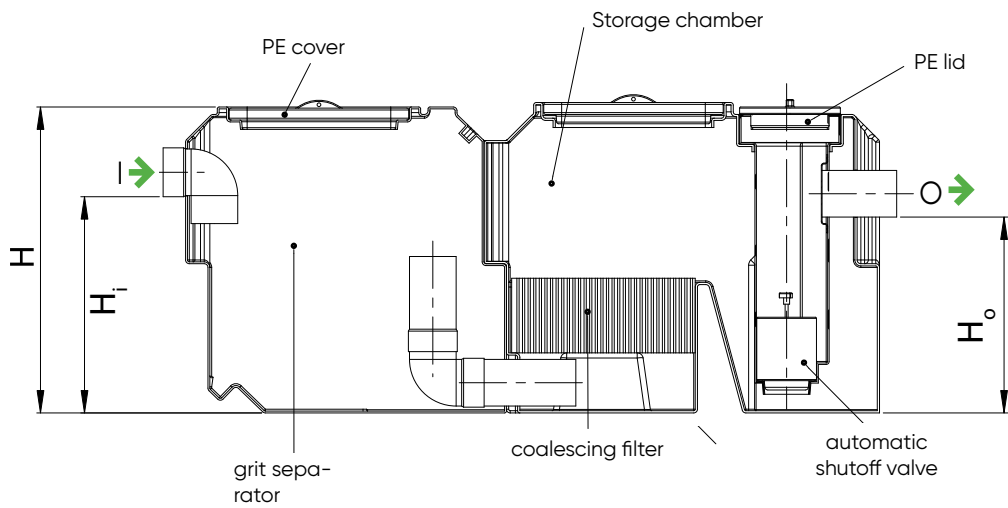
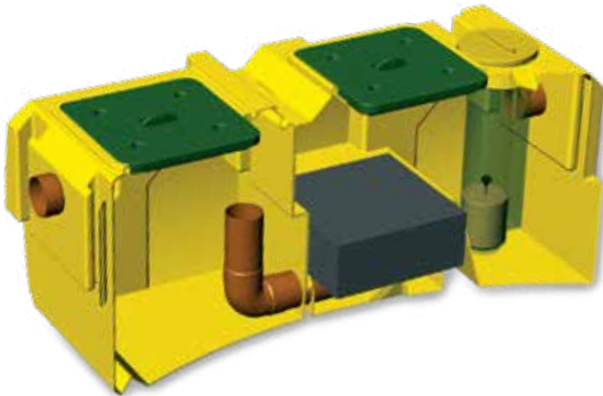

Item	Code	Flow rate (l/s)	W (cm)	L (cm)	H (cm)	H _i (cm)	H _o (cm)	∅ _i and ∅ _o (mm)
OTTO-PE 015	IS00880	1,5	80	185	82,5	58	53	125
OTTO-PE 030	IS00881	3,0	80	210	82,5	58	53	125
OTTO-PE 045	IS00882	4,5	100	218	102,5	77	72	140
OTTO-PE 060	IS00883	6,0	100	233	102,5	77	72	140

Accessory	Code
Grease level alarm kit	ISSEN15

PRODUCT DESCRIPTION

Polyethylene packaged Otto Pe oil and hydrocarbon separator, composed by two separate modules joined together, containing the grit separator, coalescing filter and automatic shutoff valve, has to be used mainly as a treatment device for wastewater from downpipes and runoff from forecourts, garages and machine shops.

WASTEWATER INLET

featuring baffle designed to dampen violent flows.

GRIT SEPARATOR

First chamber designed for settling of inert matter that is heavier than water, and simplifying subsequent stages.

COALESCING FILTER

capable of improving flotation process efficiency in order to filter out small particles of emulsified oil, which would be difficult to remove otherwise; the standard version is provided of plastic filtering material.

AUTOMATIC SHUTOFF VALVE

device designed to close the outlet pipe automatically by means of a special kind of closure; the pipe is shut off as soon as the separated oil and hydrocarbon storage chamber is full.

HYDROCARBON STORAGE CHAMBER

compartment in which the pollutants sediment and remain until removal time.

INSTALLATION (p 74)

PIT

Dig a suitably sized pit. Line the bottom of the pit with a 10 cm thick layer of sand or other aggregate with a particle size ranging from 0 to 5 mm. Dampen the sand and level the surface on which the unit will sit before lowering it inside.

CONNECTIONS

Connect the Otto-Pe outlet to an inspection chamber with a PVC pipe. Connect the drains to the Otto Pe inlet with a PVC pipe.

FILLING

Fill the Otto-Pe unit with clean water to start the separation process properly.

BACKFILLING AND FINISHING:

Backfill around the sides with damp sand or other aggregate with a particle size ranging from 0 to 5 mm. Lay a 5 cm thick lightweight concrete cover on top of the unit, or finish with a reinforced concrete slab if the area is subject to vehicular traffic, making sure a suitable inspection chamber is installed for the unit. In the standard version, Otto Pe units can be installed with a maximum covering of 50 cm from the top of the actual units.

USE

START-UP

The Otto-Pe hydrocarbon separator is a treatment device designed for pipes carrying wastewater full of oils and hydrocarbons, mainly coming from garages, machine shops, forecourts and downpipes. When installed between the drain line and final destination, Otto Pe protects the latter from pollution.

CHECKING AND MAINTENANCE:

Once the Otto-Pe unit has been installed, check its handling of the hydraulic load by allowing the wastewater to flow through. Check the quality of the effluent at regular intervals and where necessary, depending on the results of the analysis, remove oils and hydrocarbons that have been separated and are being held partly in the grit separator and partly in the main chamber. Remove sand and inert matter settled inside the grit separator regularly. When removing pollutant material, clean the filtering equipment with a water blaster. Make sure you dispose of all pollutant material through specialized companies.

OPTIONAL

Oil level alarm system.

COMPLIANCE WITH STANDARD

CE - UNI EN 858

OIL TRAP

Oil and hydrocarbon separator class 2



PRODUCT CATEGORY

OIL TRAP

PRODUCT NAME

OIL TRAP

APPLICATION

Treatment of runoff from outside areas, garages, surfaces associated with industrial or artisan manufacturing, car parks or car washes

CAPACITY

0,5 - 30 l/sec

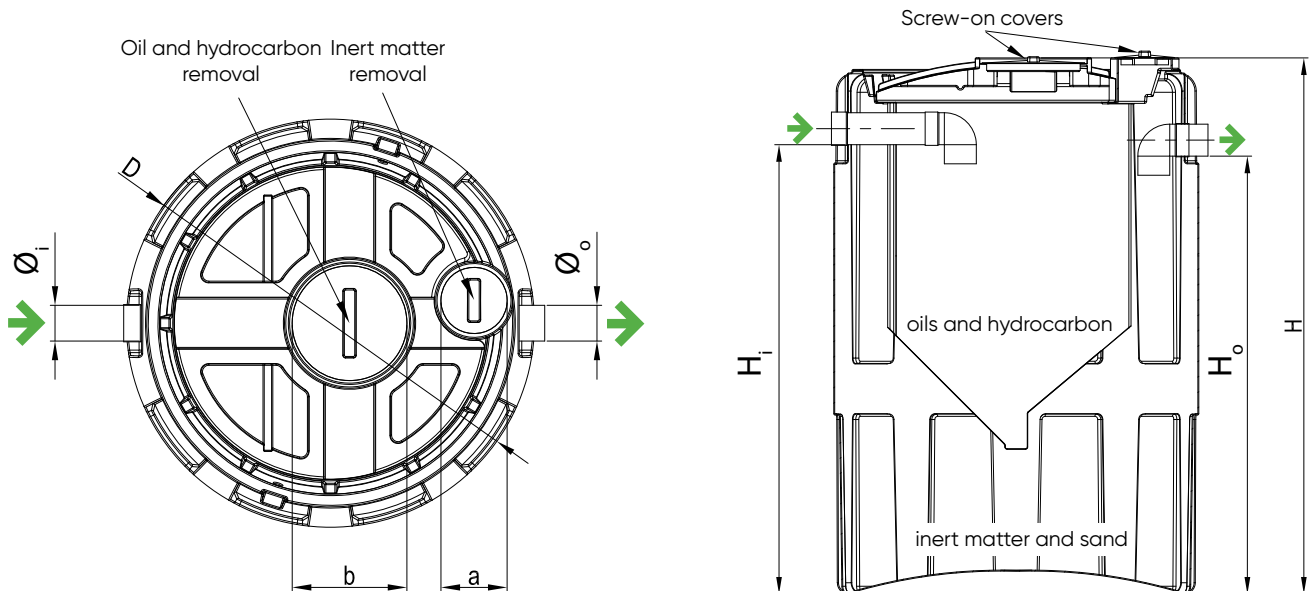

Item	Code	Flow rate (l/s)	Uncovered surface area (m ²)	Covered surface area (m ²)	Capacity (l)	D (cm)	H (cm)	a (cm)	b (cm)	Hi (cm)	Ho (cm)	Ø _i and Ø _o (mm)
Type 400	IS720HT	0,5	50	150	400	80	80	-	300	60	55	100
Type 800	IS721HT	1	100	300	600	80	120	-	300	100	95	100
Type 1000	IS722HT	1,5	150	450	1.000	120	120	-	400	100	95	100
Type 1500	IS723HT	2	200	600	1.500	120	150	-	400	128	123	125
Type 2000	IS724HT	3	300	900	2.000	120	190	-	400	168	163	125
Type 3000	IS725HT	4,5	450	1.350	3.000	160	185	200	400	147	142	125
Type 4000	IS726HT	6	600	1.800	4.000	160	235	200	400	197	192	140
Type 5000	IS727HT	10	1.000	3.000	5.000	190	215	200	400	177	172	140
Type 6000	IS728HT	15	1.500	4.500	6.000	190	255	200	400	216	211	160
Type 8000	IS729HT	20	2.000	6.000	8.000	220	260	20	40	211	206	160
Type 9000	IS730HT	25	2.500	7.500	9.000	220	285	20	40	236	231	160
Type 10000	IS731HT	30	3.000	9.000	10.000	220	310	20	40	261	256	200

Accessory

Code

Grease level alarm kit ISSEN15

PRODUCT DESCRIPTION

HT Oil Trap, pick flow 0,5-30 l/sec, featuring one piece construction made from polyethylene, complete with screw on covers both for central inspection and removing oils, hydrocarbons and floating material, and for side inspection and removing sand and inert matter. Featuring PVC inlet pipe section; PVC treated water outlet pipe section with external neoprene seal; inlet and outlet T fitting (or elbow fitting) and inspection cover.

INSTALLATION (p. 74)

CONNECTIONS

Connect the outlet to an inspection chamber with a PVC pipe. Connect the wastewater pipes to the oil trap inlet in order to start the treatment process.

FILLING

Fill the Oil Trap with clean water to start the separation process properly.

BACKFILLING AND FINISHING

Backfill around the sides with damp sand or other aggregate with a particle size ranging from 0 to 5 mm. If necessary, top the backfill with a 5 cm thick cement layer or 25 cm thick reinforced concrete layer in case of vehicular traffic.

USE

CHECKING AND MAINTENANCE

Make sure that installation is carried out as prescribed in a professional manner. Check at regular intervals to make sure no coarse matter is blocking the wastewater inlet or treated water outlet through the openings in the top fitted with screw on covers. At regular intervals, open the smaller screw on cover to make sure that the level of settled sand does not rise above the bottom of the settling chamber. At least once a year make sure that oils, hydrocarbons and floating material have not filled the whole central chamber.

OPTIONAL

Oil level alarm system.

COMPLIANCE WITH STANDARD

UNI EN 858

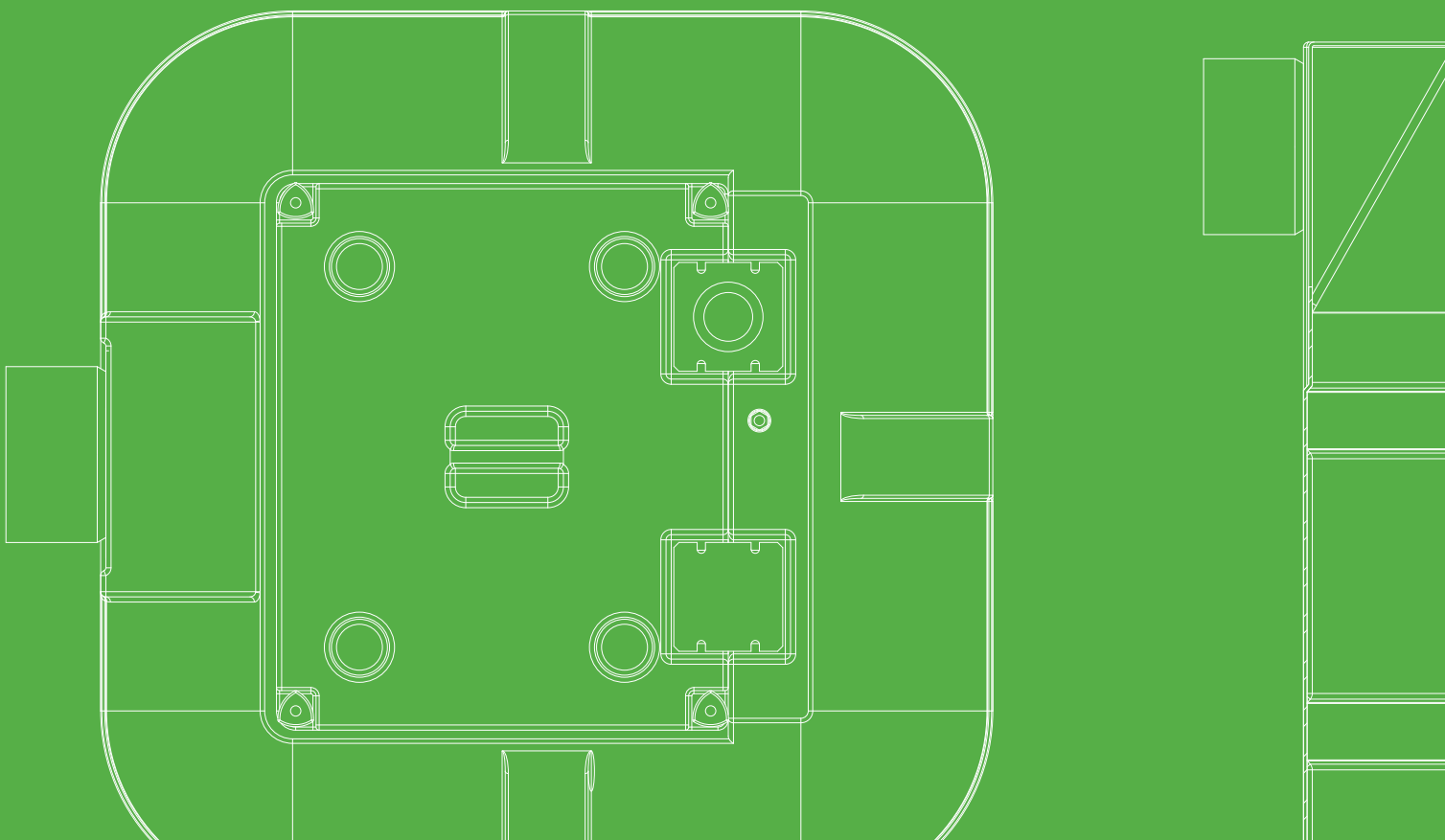
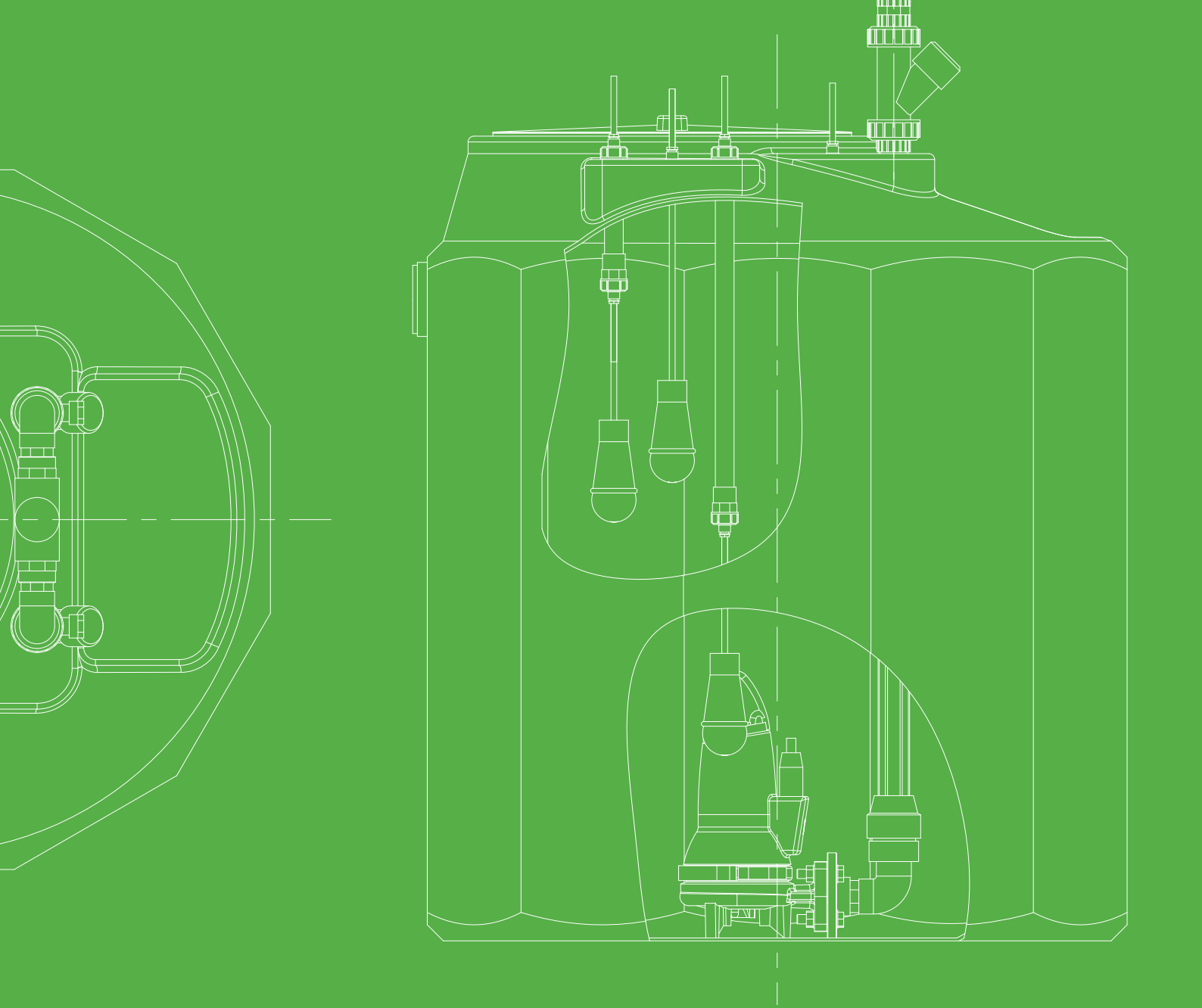

Lifting stations



Lifting stations are used to convey wastewater to final destination that is located in a higher position and at distance from the drainage point.

They can also be used to regulate the rate at which influent enters wastewater treatment plants to guarantee a constant flow where required. Wastewater which may be screened sewage, raw sewage or used water in general, along with rainwater or urban runoff is lifted by means of free standing motor-driven pumps installed, either alone or in pairs, in suitably sized chambers, with all necessary fittings provided. Their operation is controlled by level sensor switches and/or control panels, depending on the model.

These units can be used in conjunction with wastewater treatment plants in various ways depending on specific design requirements.

PRATICA FAMILY

Lifting stations

Type 250 - 500

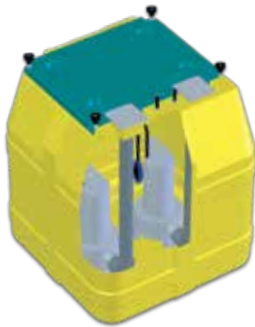

PRODUCT CATEGORY
LIFTING STATION

PRODUCT NAME
PRATICA FAMILY

APPLICATION
Lifting rain water

CHARACTERISTICS
Flow rates 0-20 m³/h
Heads 0-7 m

Type 1000



Type 250 - 500

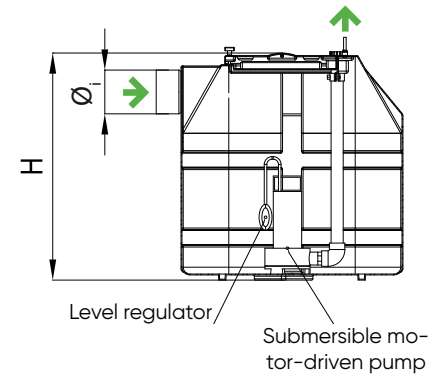
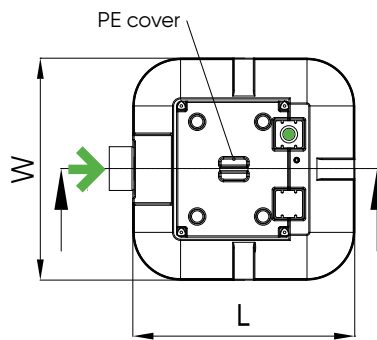

Type 1000

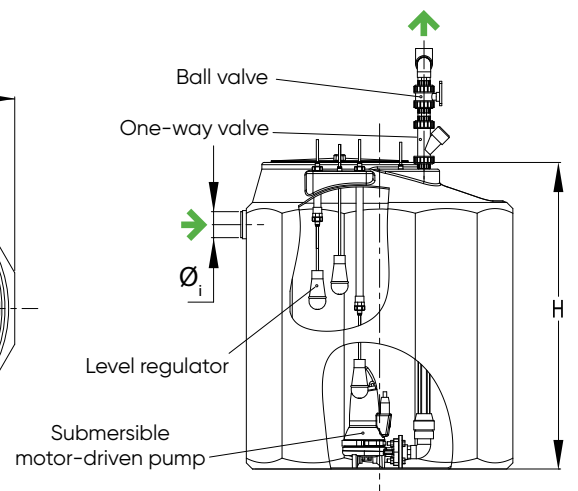
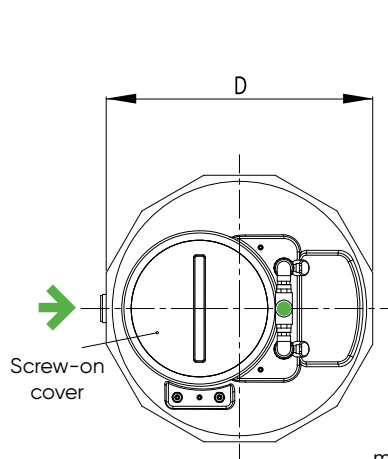

Item	Code	Capacity (l)	WxL or D (cm)	H (cm)	Ø _i (mm)	Pump delivery (³)	Height H (m)	Flow rate Q (m ³ /h)	Electrical Power 1 pump (kW)	Voltage (V)
Type 250 A1	IS04300	250	66x66	75	100	1 ½	0-7	0-10	0,38	220
Type 250 A2	IS04301	250	66x66	75	100	1 ½	0-7	0-20	0,38	220
Type 500 A1	IS04302	500	86x86	85	100	1 ½	0-7	0-10	0,38	220
Type 500 A2	IS04303	500	86x86	85	100	1 ½	0-7	0-20	0,38	220
Type 1000 A1	IS04304	1.000	120	140	100	1 ½	0-7	0-10	0,38	220
Type1000 A2	IS04305	1.000	120	140	100	1 ½	0-7	0-20	0,38	220

A1 indicates that the station is equipped with a single-motor-driven pump. A2 indicates that the station is equipped with two motor-driven pumps. Only the models Type 1000 come provided with a control box

PRODUCT DESCRIPTION

One-piece polyethylene Pratica Family lift station, complete with central cover for inspection and maintenance of pumps. The pumps, which are either single or in pairs, are designed for freestanding wet well installation and are made from a synthetic material, cast iron or stainless steel. The ball valve and non-return valve are installed on the delivery line; level regulators complete the list of accessories. Pipes, fittings and valves are made from PVC. The control box does not come as standard issue with the unit. Models with volume of 1000 liters and more are supported with electrical cases to adjust the pumps work.

INSTALLATION (p. 75)

PIT

Dig a pit large enough to house the unit. Prepare a surface to rest the unit on, lining the bottom of the pit with a 10 cm thick layer of lightweight concrete or other aggregate. Level the surface on which the units will sit before lowering them inside.

FILLING

Place the units in the middle of the pit and fill them with clean water.

BACKFILLING AND FINISHING

Use concrete to fill the pit up to the level of the water. If necessary, leave a 5 cm layer of cement or 25 cm layer of concrete on the top of the mechanism in case of vehicular traffic. If groundwater is present in the pit, or if the ground is on a gradient or near a slope, the unit must be backfilled around the sides with concrete and topped with a concrete slab; both backfill and slab must be perfectly watertight

USE

START-UP

Make sure that installation is carried out as prescribed in a professional manner. Check operation of the pumps.

CHECKING AND MAINTENANCE

At least once a year, remove the pumps from the polyethylene housing to check that the impeller is working properly.

COMPLIANCE WITH STANDARDS

EN 12050-2



PRATICA

Lifting Stations

Type 250 - 500

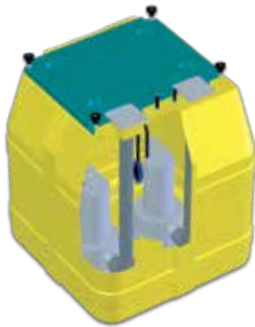

PRODUCT CATEGORY

LIFTING STATION

PRODUCT NAME

PRATICA

APPLICATION

Lifting surface water and sewage generated by civil and industrial facilities

CHARACTERISTICS

Flow rates up to 36 m³/h
Heads up to 10,5 m

Type 1000



Type 250 - 500

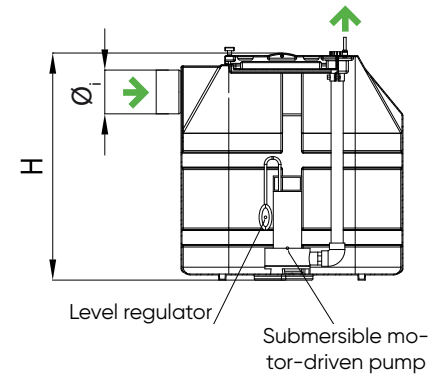
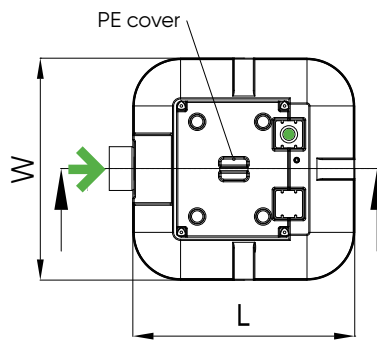

Type 1000

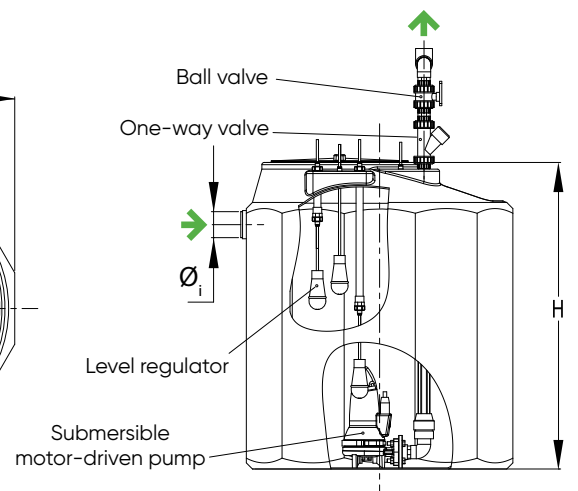
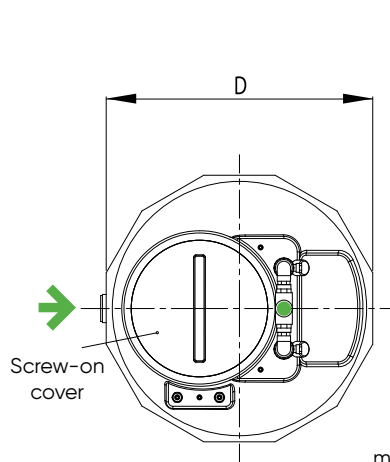

Item	Code	Capacity (l)	Users (E.I.)	WxL or D (cm)	H (cm)	Ø _i (mm)	Pump delivery (")	Height H (m)	Flow rate Q (m ³ /h)	Electrical Power 1 pump (kW)	Voltage (V)
Type 250 B1	ISO4310	250	5	66x66	75	100	1 ½	2-9	0-14	0,55	220
Type 250 B2	ISO4311	250	10	66x66	75	100	1 ½	2-9	0-28	0,55	220
Type 500 B1	ISO4312	500	15	86x86	85	100	1 ½	2-9	0-14	0,55	220
Type 500 B2	ISO4313	500	20	86x86	85	100	1 ½	2-9	0-28	0,55	220
Type 1000 B1	ISO4112	1.000	30	120	140	100	1 ½	2-10,5	0-18	0,75	220
Type 1000 B2	ISO4113	1.000	50	120	140	100	1 ½	2-10,5	0-36	0,75	220

B1 indicates that the station is equipped with a single-motor-driven pump. B2 indicates that the station is equipped with two motor-driven pumps. Only the models Type 1000 come provided with a control box

PRODUCT DESCRIPTION

One-piece polyethylene Pratica lift station, complete with central cover for inspection and maintenance of pumps.

The pumps, which are either single or in pairs, are designed for freestanding wet well installation and are made from a synthetic material, cast iron or stainless steel. The ball valve and non-return valve are installed on the delivery line; level regulators complete the list of accessories. Pipes, fittings and valves are made from PVC. The control box does not come as standard issue with the unit. Models with volume of 1000 liters and more are supported with electrical cases to adjust the pumps work.

INSTALLATION (p. 75)

PIT

Dig a pit large enough to house the unit. Line the bottom of the pit with a 10 cm-thick layer of lightweight concrete or other aggregate.

FILLING

Place the units in the middle of the pit and fill it with clean water.

BACKFILLING AND FINISHING

Use concrete to fill the pit up to the level of the water.

If necessary, leave a 5 cm layer of cement or 25 cm layer of concrete on the top of the mechanism in case of vehicular traffic. If groundwater is present in the pit, or if the ground is on a gradient or near a slope, the unit must be backfilled around the sides with concrete and topped with a concrete slab; both backfill and slab must be perfectly watertight

USE

START-UP

Make sure that installation is carried out as prescribed in a professional manner. Check operation of the pumps.

CHECKING AND MAINTENANCE

At least once a year, remove the pumps from the polyethylene housing to check that the impeller is working properly.

COMPLIANCE WITH STANDARD

EN 12050-2

PRATICA ROTO

Lifting Stations

Type 250 - 500

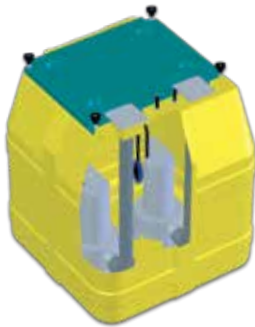

PRODUCT CATEGORY
LIFTING STATION

PRODUCT NAME
PRATICA TYPE ROTO

APPLICATION
Lifting black water and sewage

CHARACTERISTICS
Flow rates up to 14 m³/h
Heads 2 - 20 m

Type 1000



Type 250 - 500

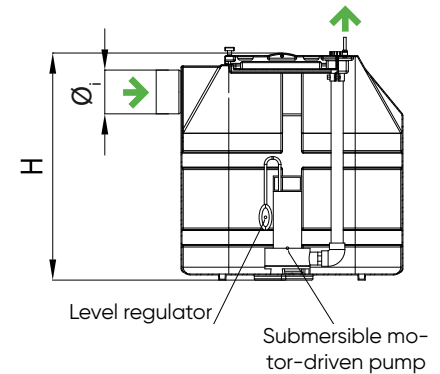
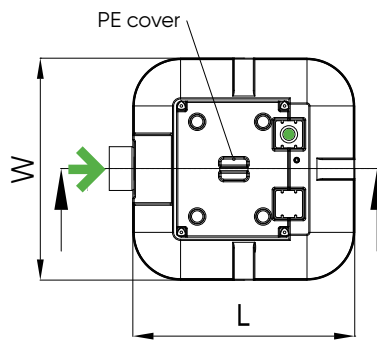

Type 1000

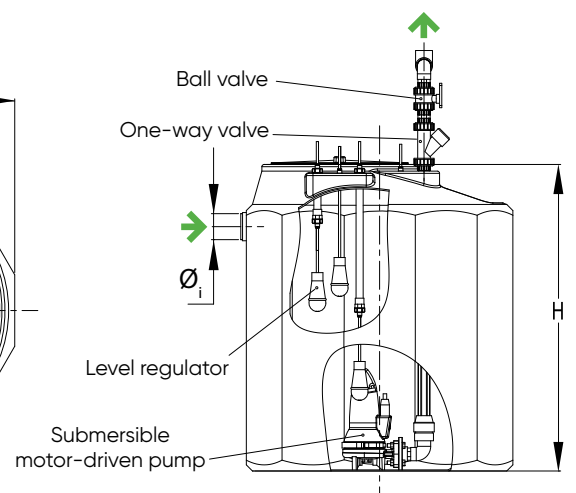
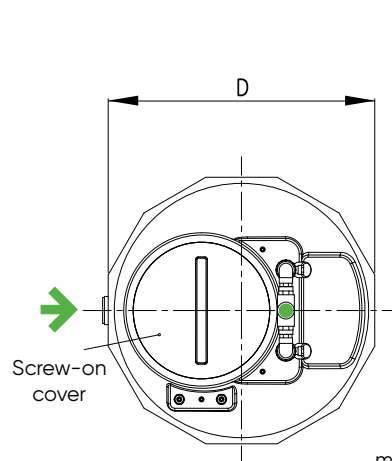

Item	Code	Capacity (l)	Users (E.I.)	WxL or D (cm)	H (cm)	Ø _i (mm)	Pump delivery (")	Height H (m)	Flow rate Q (m ³ /h)	Electrical Power 1 pump (kW)	Voltage (V)
Type 250 R1	IS04320	250	5	66x66	75	100	1 ½	2-20	0-7	1,4	220
Type 250 R2	IS04321	250	10	66x66	75	100	1 ½	2-20	0-14	1,4	220
Type 500 R1	IS04322	500	15	86x86	85	100	1 ½	2-20	0-7	1,4	220
Type 500 R2	IS04323	500	20	86x86	85	100	1 ½	2-20	0-14	1,4	220
Type 1000 R1	IS04221	1.000	30	120	140	100	1 ½	2-20	0-7	1,4	220
Type 1000 R2	IS04222	1.000	50	120	140	100	1 ½	2-20	0-14	1,4	220

R1 indicates that the station is equipped with a single-motor-driven pump. R2 indicates that the station is equipped with two motor-driven pumps. Only the models Type 1000 come provided with a control box

PRODUCT DESCRIPTION

One-piece polyethylene Pratica Roto lift station, complete with central cover for inspection and maintenance of pumps.

The pumps, which are either single or in pairs, are designed for freestanding wet well installation and are made from a synthetic material, cast iron or stainless steel. The ball valve and non-return valve are installed on the delivery line; level regulators complete the list of accessories. Pipes, fittings and valves are made from PVC. The control box does not come as standard issue with the unit. Models with volume of 1000 liters and more are supported with electrical cases to adjust the pumps work.

INSTALLATION (p. 75)

PIT

Dig a pit large enough to house the unit. Line the bottom of the pit with a 10cm-thick layer of lightweight concrete or other aggregate.

FILLING

Place the units in the middle of the pit and fill it with clean water.

BACKFILLING AND FINISHING

Use concrete to fill the pit up to the level of the water.

If necessary, leave a 5 cm layer of cement or 25 cm layer of concrete on the top of the mechanism in case of vehicular traffic. If groundwater is present in the pit, or if the ground is on a gradient or near a slope, the unit must be backfilled around the sides with concrete and topped with a concrete slab; both backfill and slab must be perfectly watertight

USE

START-UP

Make sure that installation is carried out as prescribed in a professional manner. Check operation of the pumps.

CHECKING AND MAINTENANCE

At least once a year, remove the pumps from the polyethylene housing to check that the impeller is working properly.

COMPLIANCE WITH STANDARD

EN 12050-2

PRATICA PUBLIC

Lifting stations



PRODUCT CATEGORY

LIFTING STATION

PRODUCT NAME

PRATICA PUBLIC

APPLICATION

Lifting surface water and sewage with high flow rates

CHARACTERISTICS

Flow rates up to 54 m³/h

Heads 2- 24 m

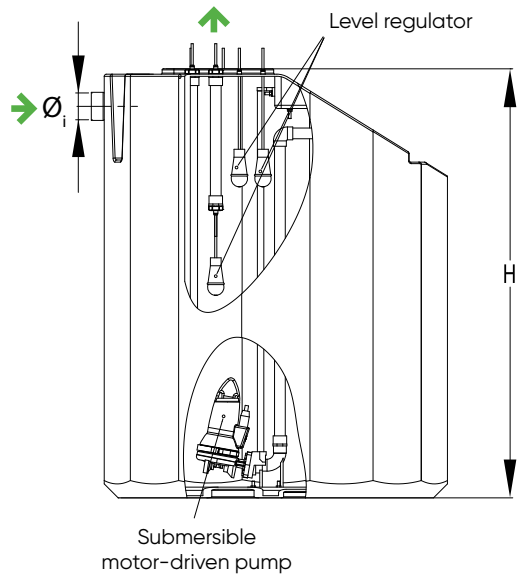
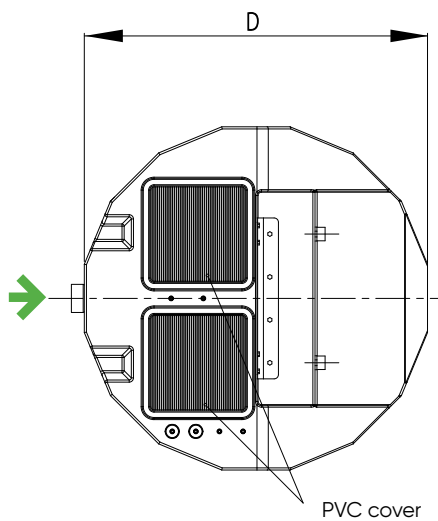

Item	Code	Capacity (l)	D (cm)	H (cm)	Ø _i (mm)	Pump delivery (")	Height H (m)	Flow rate Q (m ³ /h)	Electrical Power 1 pump (kW)	Voltage (V)
3000 B2	IS04600	3.000	160	200	200	2	2 - 15	0 - 42	1,1	380
3000 E2	IS04601	3.000	160	200	200	2	2 - 11	0 - 36	1,1	380
3000 R2	IS04602	3.000	160	200	200	1½	9 - 24	0 - 32	2,3	380
4000 B2	IS04603	4.000	160	240	200	2	3 - 18	0 - 48	1,5	380
4000 E2	IS04604	4.000	160	240	200	2	2 - 13	0 - 42	1,5	380
4000 R2	IS04605	4.000	160	240	200	1½	9 - 24	0 - 32	2,3	380
5000 B2	IS04606	5.000	160	280	200	2	5 - 20	0 - 54	2,2	380
5000 E2	IS04607	5.000	160	280	200	2	3 - 17	0 - 48	2,2	380
5000 R2	IS04608	5.000	160	280	200	1½	9 - 24	0 - 32	2,3	380

PRODUCT DESCRIPTION

One-piece polyethylene Pratica Public lift station, complete with central cover for inspection and maintenance of pumps.

The pumps, which are either single or in pairs, are designed for freestanding wet well installation and are made from a synthetic material, cast iron or stainless steel. The ball valve and non-return valve are installed on the delivery line; level regulators complete the list of accessories. Pipes, fittings and valves are made from PVC. The control box does not come as standard issue with the unit. Models with volume of 1000 liters and more are supported with electrical cases to adjust the pumps work.

INSTALLATION (p. 75)

PIT

Dig a pit large enough to house the unit. Line the bottom of the pit with a 10 cm thick layer of lightweight concrete or other aggregate.

FILLING

Place the units in the middle of the pit and fill it with clean water.

BACKFILLING AND FINISHING

Use concrete to fill the pit up to the level of the water.

If necessary, leave a 5 cm layer of cement or 25 cm layer of concrete on the top of the mechanism in case of vehicular traffic. If groundwater is present in the pit, or if the ground is on a gradient or near a slope, the unit must be backfilled around the sides with concrete and topped with a concrete slab; both backfill and slab must be perfectly watertight

USE

START-UP

Make sure that installation is carried out as prescribed in a professional manner. Check operation of the pumps.

CHECKING AND MAINTENANCE

At least once a year, remove the pumps from the polyethylene housing to check that the impeller is working properly.

COMPLIANCE WITH STANDARD

EN 12050-2

Activated sludge systems



The treatment process is biological and relies on the action of aerobic bacteria, which feed off the organic content of the incoming wastewater. Activated sludge systems are split into:

Aeration zone where air is injected into the sewage by several fine bubble air diffusers (ISEA patented) fed by a micro-perforated EPDM diaphragm compressor to maintain the growth of bacteria.

Settling zone, where the larger sludge floc separates from the effluent flow and partly recycled in the aeration section. Surface water is evacuated with hydraulic flux through the outfall. Settling of solids contained in wastewater coming from the aeration zone occurs after they reach a special still zone inside the unit.

These systems can be complemented with pre or post-treatments to improve overall treatment efficiency, depending on the properties of the wastewater and type of final destination

Activated sludge systems are particularly suitable for small and medium sized communities as they offer the following advantages:

- very high effluent quality standard;
- consistent effluent properties;
- accessible facilities;
- Simple to run and maintain;
- low electricity consumption.
- high adaptability to different type of grounds, even difficult ones;
- low sludge surplus production rate;
- modularity of system elements, possibility to increase the capacity;
- lower transport costs thanks to containerization of modules;
- easily integrating modules;
- reusable and re-transportable modules.

SUPER PLUS

Activated sludge system



PRODUCT CATEGORY

Activated sludge system

PRODUCT NAME

SUPER PLUS

APPLICATION

Non-collective treatment of domestic wastewater, from one housing unit (around 5 person) up to 25 users. High effluent quality for discharge into surface water body

NO. OF USERS SERVED

5 - 25 E.I.

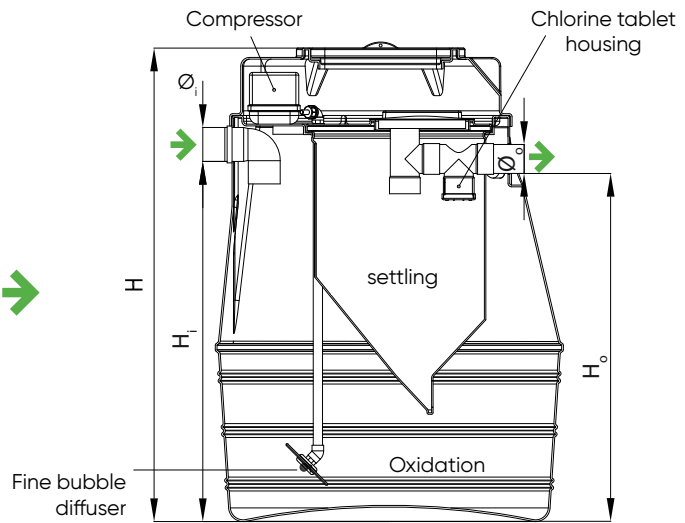
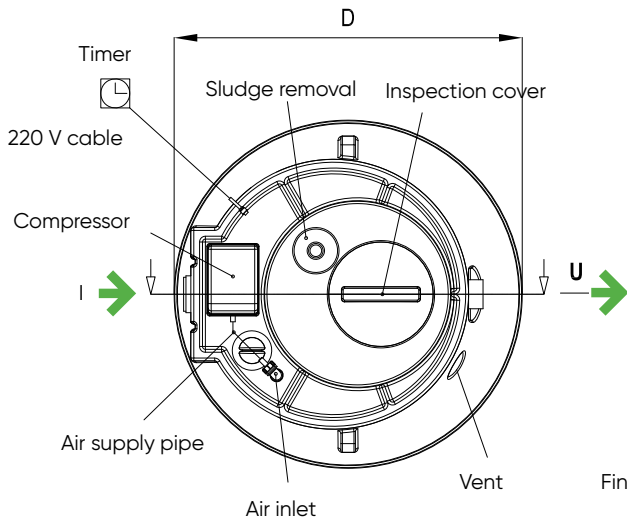

Item	Code	Users (E.I.)	D (cm)	H (cm)	H _i (cm)	H _o (cm)	V _{ox} (m ³)	V _{sett} (m ³)	Ø _i and Ø _o (mm)	Power (W)
SUPER PLUS S.1	IS09220	5	120	142	105	100	0,73	0,17	100	30
SUPER PLUS S.2	IS09221	10	120	162	125	120	1,14	0,25	100	40
SUPER PLUS S.3	IS09222	15	120	202	165	160	1,44	0,5	125	40
SUPER PLUS S.4	IS09223	20	160	187	140	135	2,47	0,5	140	55
SUPER PLUS S.5	IS09224	25	160	222	175	170	3,47	0,6	140	85

Delivery includes: compressor, timer, activation enzymes, and chlorine disinfection tablet.

PRODUCT DESCRIPTION

One-piece polyethylene Super Plus activated sludge system, made entirely with polyethylene; designed for domestic effluent treatment, comprising 3 stages: an aeration stage during which oxygen is injected into the sewage by fine bubble in a special still zone and a stage during which the resulting sludge is digested. Super Plus is equipped with a system proposed to fit the ventilation system, a polyethylene cover and timer. In case of need, it is possible to purchase a 400 mm riser. The cycle details are presented here below:

AERATION

Aeration of influent with the introduction of air sent by a whisper quiet diaphragm compressor located in the special housing created inside the unit; air is distributed in fine bubbles by means of non-clogging diffusers made from EPDM.

SETTLING

Settling of solids contained in wastewater coming from the aeration zone, achieved with suitable retention times in a special still zone created inside the unit.

DIGESTION

Digestion of sludge that is generated during the settling stage and builds up on the bottom of the aeration chamber. The digestion process occurs to the sludge produced through settling the elements that cannot be decomposed

INSTALLATION (p. 74)

PIT

Dig a suitably sized pit. Line the bottom of the pit with a 10 cm thick layer of sand or other aggregate with a particle size ranging from 0 to 5 mm. Dampen the sand and level the surface on which the unit will sit before lowering it inside.

CONNECTIONS

Connect the Super Plus outlet to an inspection chamber with a PVC pipe. Connect the wastewater pipes to the Super Plus inlet with a polypropylene Pipe.

FILLING

Fill Super Plus with clean water to start the biological process properly.

BACKFILLING AND FINISHING

Backfill around the sides with damp sand or other aggregate with a particle size ranging from 0 to 5 mm. Lay a 5 cm thick lightweight concrete cover on top of the unit, or finish with a reinforced concrete slab at least 25 cm thick if the area is subject to vehicular traffic. In the event no vent pipe has been installed in the bathrooms, install a trap upstream from the system. To stop foul smells travelling back into bathrooms, always place a trap upstream from the system. If bathroom drains are not connected to a vent pipe, you will need to connect a 10 mm PVC pipe to the system's safety vent and run it up to the height of the dwelling's roof. The use of riser may be required to fit the station 25 cm underneath the topsoil or in case of foot traffic areas.

ELECTRICAL CONNECTION

Make the electrical connection by installing a 220 Volt line to power the compressor, making sure that all connections are waterproof.

START-UP

Once you have finished installing the system, check that the compressor and air diffuser are working correctly. To get the system up and running quicker, place the freeze dried bacteria kit inside the aeration zone. Place the chlorine tablet in the relevant housing located on the outlet pipe.

USE

CHECKING AND MAINTENANCE

Make sure that there are no areas in the settling tank where sludge is allowed to stagnate as this can give rise to anaerobic processes. Place a new chlorine tablet in the relevant housing every three months and approximately every six months call in a specialist firm to remove the surplus sludge. Make sure bathrooms are fitted with vent pipes; alternatively, have a trap or a new vent pipe installed upstream from the system.

COMPLIANCE WITH STANDARD

2004/108/CE - 2006/95/CE

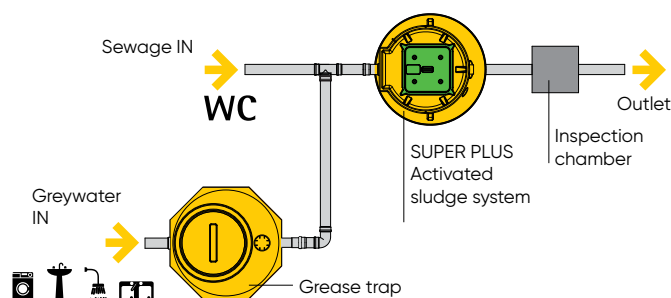

SUPER PLUS MIX

Activated sludge system



PRODUCT CATEGORY

Activated sludge system

PRODUCT NAME

SUPER PLUS MIX

APPLICATION

Non-collective treatment of domestic wastewater, from one housing unit (around 5 person) up to 30 users. Recommended in specific cases when kitchen and WC wastewater are mixed; high effluent quality for discharge into surface water body

NO. OF USERS SERVED

5 - 30 E.I.

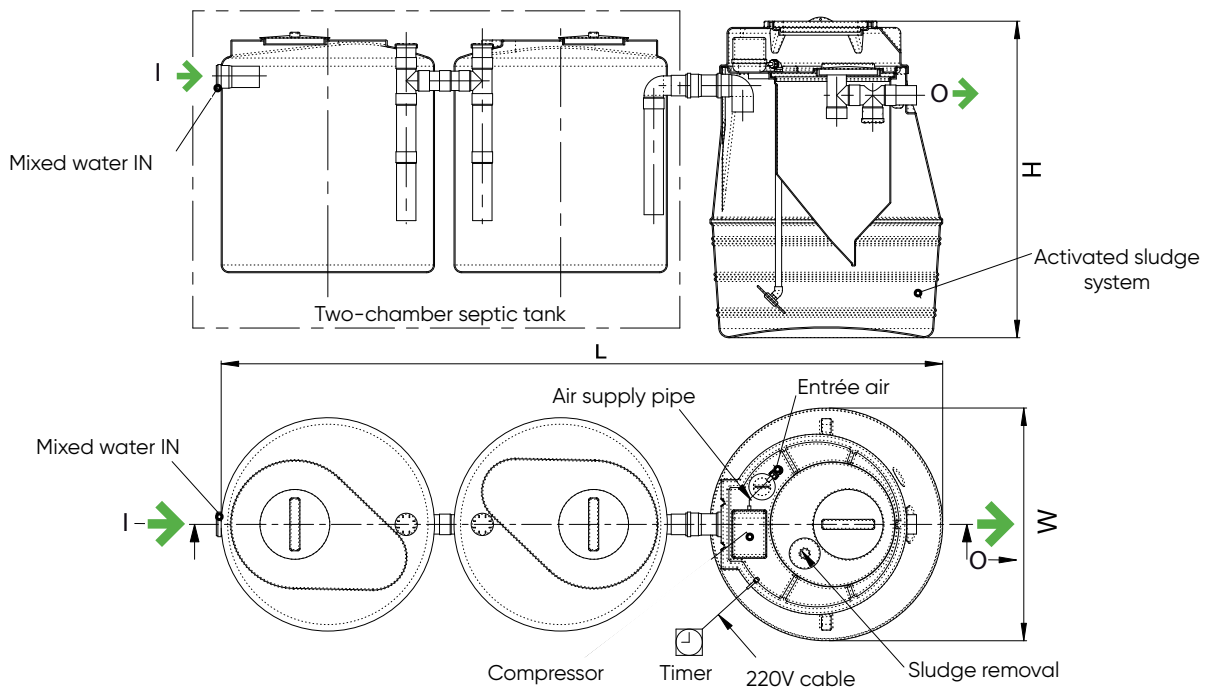

Item	Code	Users (E.I.)	Two-chambers septic tank	Activated sludge system	W (cm)	L (cm)	H (cm)
S.M.1	IS09400	5	Type 400	Super Plus S.1	120	340	142
S.M.2	IS09401	10	Type 800	Super Plus S.1	120	340	142
S.M.3	IS09402	15	Type 1000	Super Plus S.2	120	420	162
S.M.4	IS09403	20	Type 1500	Super Plus S.3	120	420	202
S.M.5	IS09404	25	Type 2000	Super Plus S.4	160	460	195
S.M.6	IS09405	30	Type 3000	Super Plus S.5	160	520	222

Delivery includes: compressor, timer, activation enzymes, and chlorine disinfection tablet.

PRODUCT DESCRIPTION

Super Plus Mix polyethylene packaged activated sludge system, suitable for treating domestic wastewater generated by dwellings with combined sewage/greywater drainage (sewage from toilets not separated from greywater from kitchens, showers, washbasins and washing machines).

The system is made up of:
two-chamber septic tank for the pre-treatment of combined sewage/ greywater;
Super Plus Mix activated sludge systems to complete sewage treatment.

The process includes 4 stages:
first stage consists on pre-treatment in two-chamber septic tank.

Then, inside the Super Plus Mix station have place two main actions respectively: an aeration stage during which oxygen is injected into the sewage by fine bubble air diffusers fed by a diaphragm compressor and a settling stage in a special still zone. Super Plus Mix is equipped with a system predisposed to fit the ventilation system, a polyethylene cover with gasket and compressor setting pad. In case of need, it is possible to purchase a 400 mm riser.

The cycle details are presented here below:

PRE-TREATMENT

This stage is carried out by a two-chamber septic tank designed both to retain floating material and to partially reduce organic loading. The cycle inside the Super Plus Mix system, placed downstream from the pre-treatment unit, is the following:

AERATION

After the pre-treatment stage starts the aeration process of sewage entering the Super Plus Mix unit with the introduction of air sent by a whisper-quiet diaphragm compressor located in the special housing created inside the unit; air is distributed in fine bubbles by means of non-clogging diffusers made from EPDM.

SETTLING

Settling of solids contained in wastewater coming from the aeration zone, achieved with suitable retention times in a special still zone created inside the unit.

DIGESTION

Digestion of sludge that is generated during the settling stage and builds up on the bottom of the Super Plus Mix aeration chamber. The digestion process occurs to the sludge produced through settling the elements that cannot be decomposed.

INSTALLATION (p. 74)

PIT

Dig a suitably sized pit. Line the bottom of the pit with a 10 cm thick layer of sand or other aggregate with a particle size ranging from 0 to 5 mm. Dampen the

sand and level the surface on which the unit will sit before lowering it inside.

CONNECTIONS

Connect the Super Plus Mix outlet to an inspection chamber with a PVC pipe.

Connect the wastewater pipes to the Super Plus Mix inlet with a polypropylene pipe.

FILLING

Fill units with clean water to start the biological process properly.

BACKFILLING AND FINISHING

Backfill around the sides with damp sand or other aggregate with a particle size ranging from 0 to 5 mm. Lay a 5 cm thick lightweight concrete cover on top of the unit, or finish with a reinforced concrete slab at least 25 cm thick if the area is subject to vehicular traffic. In the event no vent pipe has been installed in the bathrooms, install a trap upstream from the system. To stop foul smells travelling back into bathrooms, always place a trap upstream from the system. If bathroom drains are not connected to a vent pipe, you will need to connect a 10 mm PVC pipe to the system's safety vent and run it up to the height of the dwelling's roof. The use of riser may be required to fit the station 25 cm underneath the topsoil or in case of foot traffic areas.

ELECTRICAL CONNECTION

Make the electrical connection by installing a 220 Volt line to power the compressor, making sure that all connections are waterproof.

START-UP

Once you have finished installing the system, check that the compressor and air diffuser are working correctly.

To get the system up and running quicker, place the freeze-dried bacteria kit inside the aeration zone.

USE

CHECKING AND MAINTENANCE

Check at regular intervals to make sure no coarse matter is blocking the two chamber septic tank's sewage inlet or treated water outlet and that the sludge and grease level is not allowed to reach the base of the outlet pipe section. Make sure that there are no areas in the Super Plus Mix settling tank where sludge is allowed to stagnate as this can give rise to anaerobic processes; place a new chlorine tablet in the Super Plus Mix unit's relevant housing approximately every three months. Call in a specialist firm to remove the sludge and grease from the two-chamber septic tank and surplus sludge from the Super Plus Mix unit approximately at least once a year.

COMPLIANCE WITH STANDARD

2006/42/CE - 2004/108/CE - 2006/95/CE

COMPACT

Activated sludge systems



PRODUCT CATEGORY

Activated sludge system

NOM PRODUIT

COMPACT

APPLICATION

Non-collective treatment of domestic wastewater, intended to serve from 32 up to 45 users. High effluent quality for discharge into surface water body.

NO. OF USERS SERVED

32 – 45 E.I.

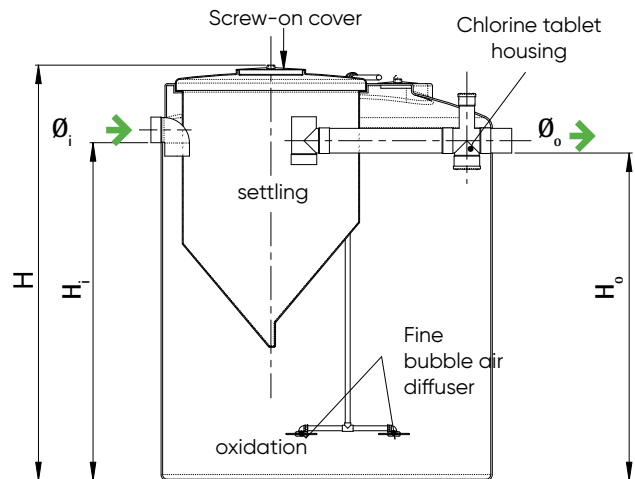
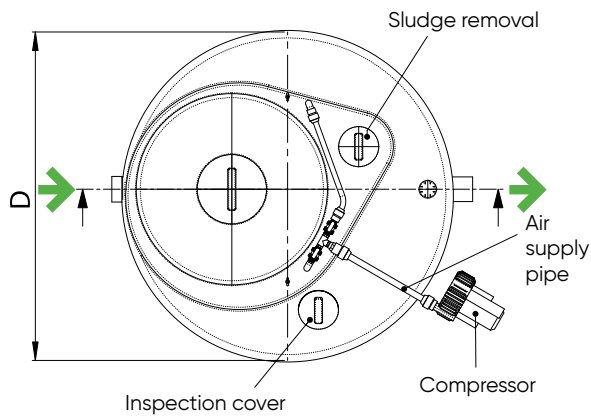

Item	Code	Users (E.I.)	D (cm)	H (cm)	Hi (cm)	Ho (cm)	V ox (m³)	V sett (m³)	Ø _i and Ø _o (mm)	Power (W)
F.A.6	IS08015	32	215	220	173	168	4,7	1,3	140	200
F.A.7	IS08016	45	215	270	217	212	6,7	1,7	160	700

Delivery includes: timer, activation enzymes, and chlorine disinfection tablet. Compressor needs to be installed outdoors and under cover.

PRODUCT DESCRIPTION

Polyethylene packaged Compact activated sludge system, suitable for treating domestic wastewater; treats sewage for subsequent discharge into surface water body; comprising an aeration stage during which oxygen is injected into the sewage by fine bubble air diffusers fed by a compressor; a settling stage in a special still zone; Compact is equipped with a system predisposed to fit the ventilation system, a polyethylene cover with gasket and compressor setting pad. In case of need, it is possible to purchase a 400 mm riser.

The cycle details are presented here below:

AERATION

Aeration of influent with the introduction of air sent by a compressor (blower) to be located in a suitable housing near the tank; air is distributed in fine bubbles by means of non-clogging diffusers made from EPDM.

SETTLING

Settling of solids contained in wastewater coming from the aeration zone, achieved with suitable retention times in a special still zone created inside the unit.

DIGESTION

Digestion of sludge that is generated during the settling stage and builds up on the bottom of the aeration chamber. The digestion process occurs to the sludge produced through settling the elements that cannot be decomposed

INSTALLATION (p. 74)

PIT

Dig a suitably sized pit. Line the bottom of the pit with a 10cm-thick layer of sand or other aggregate with a particle size ranging from 0 to 5 mm. Dampen the sand and level the surface on which the Compact unit will sit.

CONNECTIONS

Connect the Compact unit outlet to an inspection chamber with a PVC pipe. Connect the wastewater pipes to the Compact unit inlet with a polypropylene

or PVC pipe.

FILLING

Fill the Compact unit with water to start the biological process properly.

BACKFILLING AND FINISHING

Backfill around the sides with damp sand or other aggregate sized between 0 and 5 mm. Connect the compressor to the unit using the polypropylene pipe, which should be inserted in the relevant fittings, making sure the site where it is located is dry and positioned higher up than the wastewater outlet. Top the backfill with a 5cm thick lightweight concrete slab, or, if the area is subject to vehicular traffic, produce a 25 cm thick reinforced concrete slab. In case there is no air ventilation in the toilet, connect the unit's vent to a 100 mm PVC vent pipe, located at the roof capping level. The use of riser may be required to fit the station 25 cm underneath the topsoil or in case of foot traffic areas.

ELECTRICAL CONNECTION

Start aeration by plugging the compressor into a 220 Volt socket; concerning timer setting, numerous options are possible. It is recommended to refer to operating instructions.

START-UP

Once you have finished installing the system, check that the compressor and air diffuser are working correctly. To get the system up and running quicker, place the freeze-dried bacteria kit inside the aeration zone. Place the chlorine tablet in the relevant housing located on the outlet pipe.

USE

CHECKING AND MAINTENANCE

Make sure that there are no areas in the settling tank where sludge is allowed to stagnate as this can give rise to anaerobic processes. Once a year proceed a surplus sludge removal.

COMPLIANCE WITH STANDARD

2006/42/CE - 2004/108/CE - 2006/95/CE

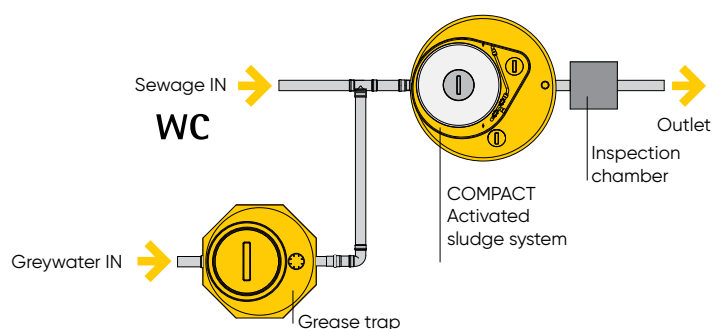

POLI 1

Activated sludge systems

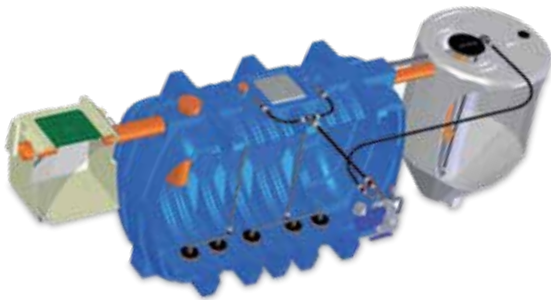

PRODUCT CATEGORY

Activated sludge system

PRODUCT NAME

POLI 1

APPLICATION

Treatment of domestic wastewater, sanitation within small settlements, up to 100 users.
High purification efficiency allowing the discharge onto land.

NO. OF USERS SERVED

50 - 100 E.I.

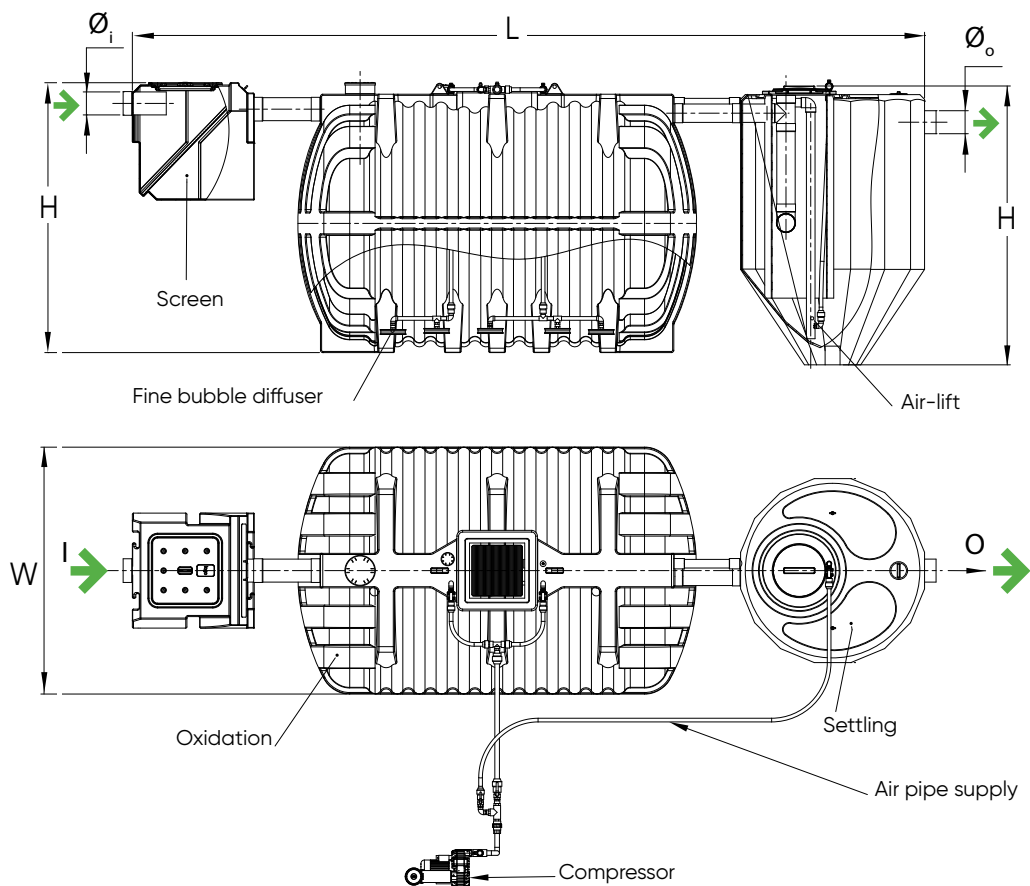

Item	Code	Users (E.I.)	W (cm)	L (cm)	H (cm)	V _{ox} (m³)	V _{sett} (m³)	Ø _i and Ø _o (mm)	Power (kW)
A.E. 50 (220V)	IS09022	50	186	610	212	6	2,5	160	0,7
A.E. 50 (380V)	IS90221	50	186	610	212	6	2,5	160	0,7
A.E. 75 (380V)	IS09032	75	196	700	240	8	4,0	160	1,1
A.E. 100 (380V)	IS09023	100	214	710	240	10	4,0	200	1,5

PRODUCT DESCRIPTION

Poli 1 activated sludge system, entirely made of polyethylene with 2 chamber structure which comprise: a reinforced ribbed tank and a cylindrical-conical shaped module. Suitable for treating wastewater coming from small settlements, communities, commercial centres etc. The discharge can be performed into a superficial hydraulic environment, surface impoundment, grounds under examination etc. Diverse solutions are possible. The process consist on 2 main stages: the oxidation stage, during which oxygen is injected into the sewage by fine bubble air diffusers fed by a compressor and a settling stage in a special still zone. Poli 1 is equipped with a fitted with a ventilation system, a polyethylene cover with gasket and electrical cases to adjust the compressor work.

Poli 1 activated sludge system comprises: aeration chamber, where the effluents undergo an oxygen flow, which is introduced by means of non-clogging fine bubble air diffusers fitted with external compressor; settling chamber represented by a cylindrical-conical tank fitted with a diffusor tube to avoid turbulences; air-lift, a system specialised in recycling the collected from the aeration chamber with means of a PVC pipe; The system is fitted with an electric pipe and electronic setting panel to adjust the compressor work; a static screen.

The appliance's work process is described here below:

AERATION

Aeration of influent with the introduction of air sent by a compressor (air blower) to be located in a suitable housing near the tank; air is distributed in fine bubbles by means of diffusers, reinforced with double (or more, according to the model) non-clogging membrane in EPDM.

SETTLING

Settling of solids contained in wastewater coming from the aeration zone, achieved with suitable retention times in the cylindrical-conical tank

DIGESTION

Digestion of sludge that is generated during the settling stage and lifted up to the aeration chamber thanks to the air-lift system by meaning of a PVC pipe.

INSTALLATION (p. 74)

PIT

Dig a suitably sized pit. Line the bottom of the pit with a 10 cm thick layer of sand or other aggregate with a particle size ranging from 0 to 5 mm. Dampen the sand and level the surface on which the Compact unit will sit.

CONNECTIONS

Connect the Poli 1 unit outlet to an inspection

chamber with a PVC pipe.

Connect the wastewater pipes to the Poli 1 unit inlet with a Polypropylene or PVC pipe.

FILLING

Fill the Poli 1 unit with water to start the biological process properly.

BACKFILLING AND FINISHING

Backfill around the sides with damp sand or other aggregate sized between 0 and 5 mm. Connect the compressor to the unit using the polypropylene pipe, which should be inserted in the relevant fittings, making sure the site where it is located is dry and positioned higher up than the wastewater outlet. Top the backfill with a 5 cm thick lightweight concrete slab, or, if the area is subject to vehicular traffic, produce a 25 cm thick reinforced concrete slab. In case there is no air ventilation in the toilet, connect the unit's vent to a 100 mm PVC vent pipe, located at the roof capping level. The station can be fitted 25 cm and more underneath the topsoil.

ELECTRICAL CONNECTION

Start aeration by plugging the compressor into a 220 or Volt socket, according to the model; concerning timer setting, numerous options are possible. It is recommended to refer to operating instructions.

START-UP

Once you have finished installing the system, check that the compressor and air diffuser are working correctly. To get the system up and running quicker, place the freeze-dried bacteria kit inside the aeration zone. Place the chlorine tablet in the relevant housing located on the outlet pipe.

USE

CHECKING AND MAINTENANCE

Make sure that there are no areas in the settling tank where sludge is allowed to stagnate as this can give rise to anaerobic processes. Once a year proceed a surplus sludge removal.

COMPLIANCE WITH STANDARD

UNI EN 1225



POLI MAXI

Activated sludge systems

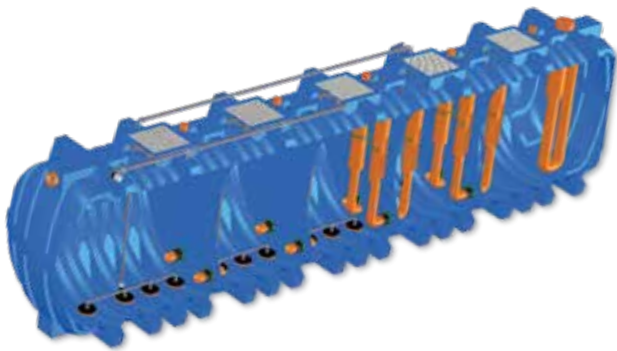

PRODUCT CATEGORY

Activated Sludge System

PRODUCT NAME

POLI MAXI

APPLICATION

Treatment of domestic wastewater within small settlements, up to 300 users.

High purification efficiency allowing the discharge onto land.

NO. OF USERS SERVED

130 - 300 E.I.

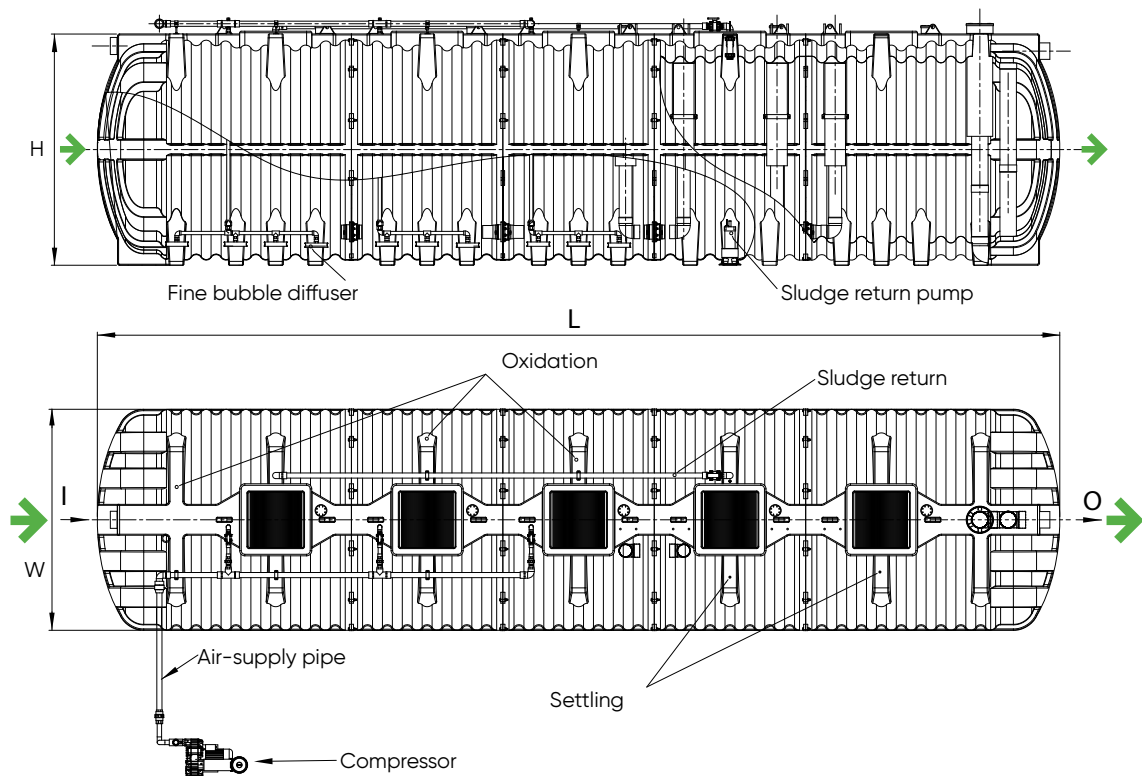

Item	Code	Users (E.I.)	W (cm)	L (cm)	H (cm)	V _{ox} (m ³)	V _{sett} (m ³)	Ø ₁ and Ø ₀ (mm)	Power (kW)
A.E. 130 (380V)	IS09026	130	214	646	228	13	8	160	1,5
A.E. 160 (380V)	IS09027	160	214	798	228	18	8	160	1,5
A.E. 210 (380V)	IS09028	210	214	950	228	23	8	200	2,2
A.E. 250 (380V)	IS09029	250	214	1102	228	23	13	200	2,2
A.E. 300 (380V)	IS09030	300	214	1254	228	28	13	200	3,0

PRODUCT DESCRIPTION

Poli Maxi activated sludge system, entirely made of polypropylene with 2 chamber structure which comprise: a reinforced ribbed tank and a cylindrical conical shaped module. Suitable for treating wastewater coming from small settlements, communities, commercial centres etc.

The discharge can be performed into a superficial hydraulic environment, surface impoundment, grounds under examination etc. Diverse solutions are possible. The process consist on 2 main stages: the oxidation stage, during which oxygen is injected into the sewage by fine bubble air diffusers fed by a compressor and a settling stage in a special still zone. Poli Maxi is equipped with a fitted with a ventilation system, a polyethylene cover with gasket and electrical cases to adjust the compressor work.

Poli Maxi activated sludge system comprises: aeration chamber, where the effluents undergo an oxygen flow, which is introduced by means of non clogging fine bubble air diffusers fitted with external compressor; settling chamber represented by a cylindrical-conical tank fitted with a diffusor tube to avoid turbulences; air-lift, a system specialised in recycling the collected from the aeration chamber with means of a PVC pipe; the system is fitted with an electric pipe and electronic setting panel to adjust the compressor work; a static screen.

The appliance's work process is described here below:

AERATION

Aeration of influent with the introduction of air sent by a compressor (air blower) to be located in a suitable housing near the tank; air is distributed in fine bubbles by means of diffusers, reinforced with double (or more, according to the model) non clogging membrane in EPDM.

SETTLING

Settling of solids contained in wastewater coming from the aeration zone, achieved with suitable retention times in the cylindrical conical tank.

DIGESTION

Digestion of sludge that is generated during the settling stage and lifted up to the aeration chamber thanks to the air-lift system by meaning of a PVC pipe.

INSTALLATION (p. 74)

PIT

Dig a suitably sized pit. Line the bottom of the pit with a 10 cm thick layer of sand or other aggregate with a particle size ranging from 0 to 5 mm. Dampen the sand and level the surface on which the Poli Maxi unit

will sit.

CONNECTIONS

Connect the Poli Maxi unit outlet to an inspection chamber with a PVC pipe.

Connect the wastewater pipes to the Poli Maxi unit inlet with a Polypropylene or PVC pipe.

FILLING

Fill the unit with water to start the biological process properly.

BACKFILLING AND FINISHING

Backfill around the sides with damp sand or other aggregate sized between 0 and 5 mm. Connect the compressor to the unit using the polypropylene pipe, which should be inserted in the relevant fittings, making sure the site where it is located is dry and positioned higher up than the wastewater outlet. Top the backfill with a 5 cm thick lightweight concrete slab, or, if the area is subject to vehicular traffic, produce a 25 cm thick reinforced concrete slab. In case there is no air ventilation in the toilet, connect the unit's vent to a 100 mm PVC vent pipe, located at the roof capping level. The station can be fitted 25 cm and more underneath the topsoil.

ELECTRICAL CONNECTION

Start aeration by plugging the compressor into a 220 or Volt socket, according to the model; concerning timer setting, numerous options are possible. It is recommended to refer to operating instructions.

START-UP

Once you have finished installing the system, check that the compressor and air diffuser are working correctly. To get the system up and running quicker, place the freeze dried bacteria kit inside the aeration zone. Place the chlorine tablet in the relevant housing located on the outlet pipe.

USE

CHECKING AND MAINTENANCE

Make sure that there are no areas in the settling tank where sludge is allowed to stagnate as this can give rise to anaerobic processes. Once a year proceed a surplus sludge removal

COMPLIANCE WITH STANDARD

UNI EN 12255-6

ANAPACKAGE Type HT

Anaerobic percolating filters



PRODUCT CATEGORY

Percolating Filter System

PRODUCT NAME

ANAPACKAGE Type HT

APPLICATION

Treatment of domestic and commercial wastewater

NO. OF USERS SERVED

Population equivalent between 6 and 18

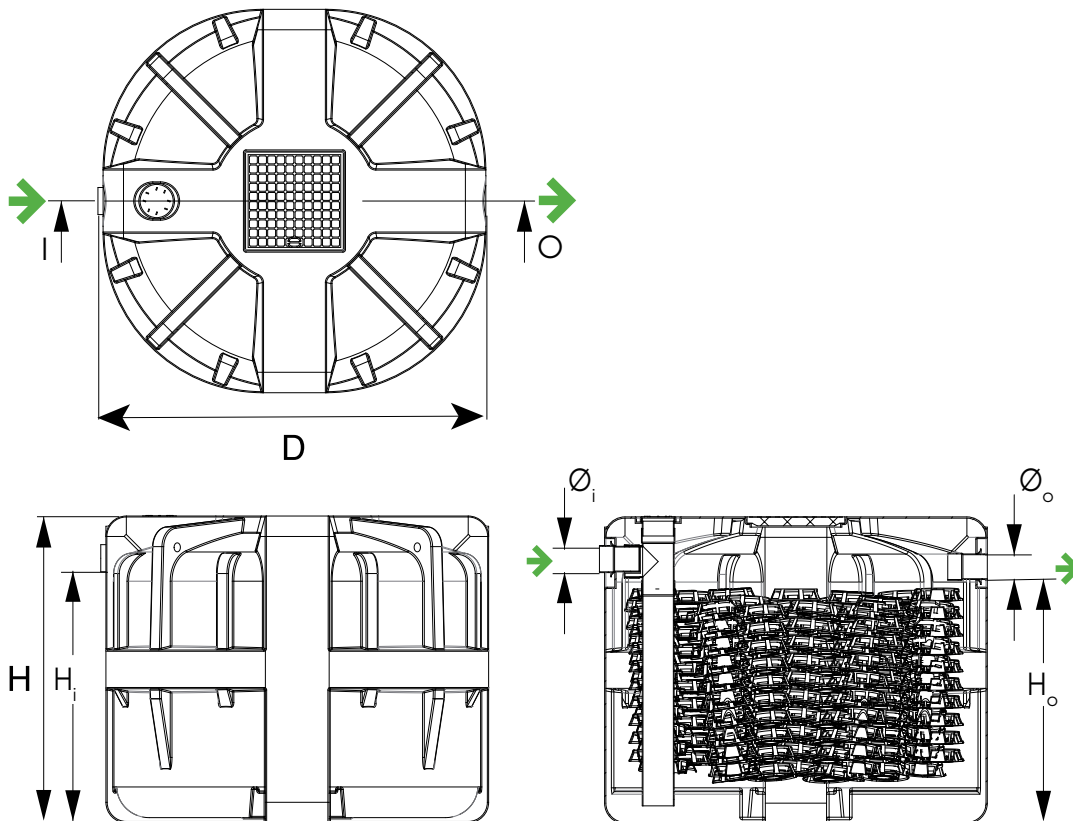

Anapackage	Code	User (A.E.)	Capacity (liters)	D (cm)	H (cm)	H _i (cm)	H _o (cm)	Ø _i and Ø _o (mm)	Inspection cover (cm)
HT6	IS70210	6	1000	120	90	70	67	100	40x40
HT12	IS70215	12	1350	120	120	100	97	100	40x40
HT18	IS70220	18	2100	150	120	97	94	125	40x40

PRODUCT DESCRIPTION

System based on the use of a polyethylene Anapackage Type HT anaerobic percolating filters, suitable for treating domestic and commercial wastewater. The complete system setup comprises a one piece polyethylene grease trap for the pre-treatment of greywater; an Imhoff septic tank for the pre-treatment of sewage; and the anaerobic percolating filter to complete sewage treatment so that the resulting effluent can be discharged to a suitable final destination.

GREASE TRAP

Designed to trap grease, oils and other floating material that can interfere with the correct performance of the subsequent biological process.

IMHOFF TANK

Responsible for primary reduction of the organic loading of the wastewater, and also providing for digestion of the sludge produced.

ANAEROBIC PERCOLATING FILTER

Suitably filled with polypropylene media featuring a high specific surface area to encourage the growth of the bacterial population responsible for purifying the wastewater.

INSTALLATION (p. 74)

PIT

Dig a suitably sized pit. Line the bottom of the pit with a 10 cm thick layer of sand or other aggregate with a particle size ranging from 0 to 5 mm. Dampen the sand.

CONNECTIONS

Connect the anaerobic percolating filter outlet to an inspection chamber with a PVC pipe. Connect the grease trap and imhoff tank outlets to the anaerobic percolating filter inlet with a PVC pipe in diameter.

Connect the greywater line to the grease trap and sewage line to the imhoff tank with polypropylene or PVC pipes.

FILLING

Fill the units with clean water to start the biological process properly.

BACKFILLING AND FINISHING

Backfill around the sides with damp sand or other aggregate sized between 0 and 5 mm. Top the backfill with a max. 40 cm thick layer of topsoil after first producing a 5 cm thick lightweight concrete slab, locating inspection chambers so that they are lined up with the screw-on covers. If the area is subject to vehicular traffic, produce a reinforced concrete slab.

ANAPACKAGE

Anaerobic percolating filters



PRODUCT CATEGORY

Percolating Filter System

PRODUCT NAME

ANAPACKAGE

APPLICATION

Treatment of domestic and commercial wastewater

NO. OF USERS SERVED

Population equivalent between 5 and 100

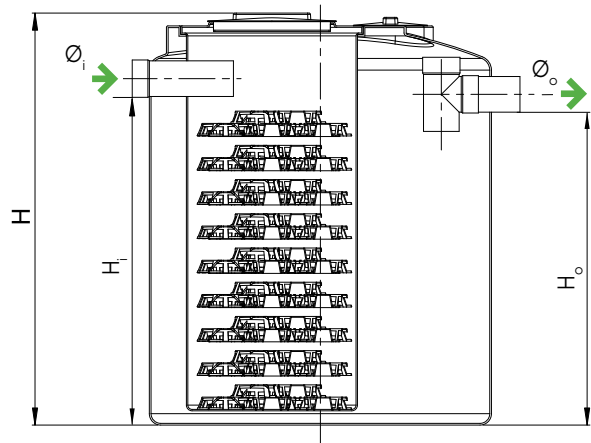
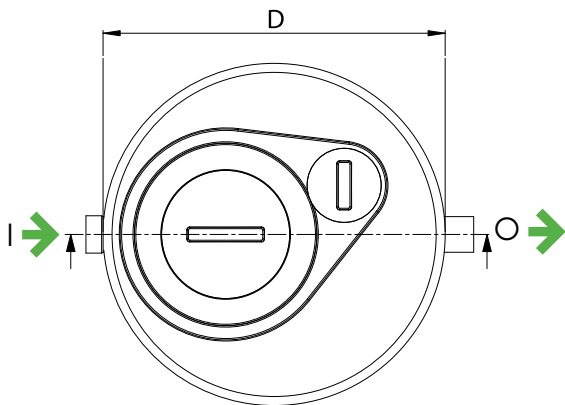

Item	Code	User (E.I.)	Capacity (liters)	D (cm)	H (cm)	H _i (cm)	H _o (cm)	Ø _i and Ø _o (mm)
Type 500	IS7001A	5	500	80	120	102	97	100
Type 1000	IS7002A	10	1.000	110	122	95	92	100
Type 1500	IS7003A	15	1.500	120	140	115	110	125
Type 2000	IS7004A	25	2.000	120	195	170	165	140
Type 3000	IS7005A	35	3.000	147	200	170	165	140
Type 4000	IS7006A	50	4.000	147	245	215	210	160
Type 6000	IS7008A	70	6.000	215	220	173	168	160
Type 8000	IS7009A	80	8.000	215	270	217	212	160
Type 10000	IS7010A	100	10.000	215	305	251	246	200

PRODUCT DESCRIPTION

System based on the use of a polyethylene Anapackage anaerobic percolating filter, suitable for treating domestic and commercial wastewater. The complete system setup comprises a one piece polyethylene grease trap for the pre-treatment of greywater; an imhoff tank for the pre-treatment of sewage; and the anaerobic percolating filter to complete sewage treatment so that the resulting effluent can be discharged to a suitable final destination.

GREASE TRAP

Designed to trap grease, oils and other floating material that can interfere with the correct performance of the subsequent biological process.

IMHOFF TANK

Responsible for primary reduction of the organic loading of the wastewater, and also providing for digestion of the sludge produced.

ANAEROBIC PERCOLATING FILTER

Suitably filled with polypropylene media featuring a high specific surface area to encourage the growth of the bacterial population responsible for purifying the wastewater.

INSTALLATION (p. 74)

PIT

Dig a suitably sized pit. Line the bottom of the pit with a 10 cm thick layer of sand or other aggregate with a particle size ranging from 0 to 5 mm. Dampen the sand.

CONNECTIONS

Connect the anaerobic percolating filter outlet to an inspection chamber with a PVC pipe. Connect the grease trap and imhoff tank outlets to the anaerobic percolating filter inlet with a PVC pipe in diameter.

Connect the greywater line to the grease trap and sewage line to the imhoff tank with polypropylene or PVC pipes.

FILLING

Fill the units with clean water to start the biological process properly.

BACKFILLING AND FINISHING

Backfill around the sides with damp sand or other aggregate sized between 0 and 5 mm. Top the backfill with a max. 40 cm thick layer of topsoil after first producing a 5 cm thick lightweight concrete slab, locating inspection chambers so that they are lined up with the screw-on covers. If the area is subject to vehicular traffic, produce a reinforced concrete slab.

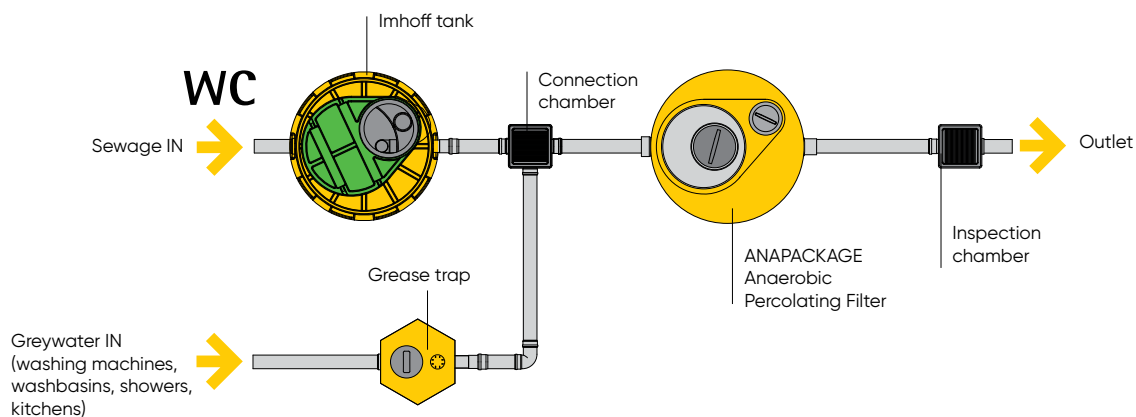

PACKAGE

Aerobic percolating filter



PRODUCT CATEGORY

Percolating Filter System

PRODUCT NAME

PACKAGE

APPLICATION

Treatment of domestic and commercial wastewater

NO. OF USERS SERVED

5 - 100 E.I.

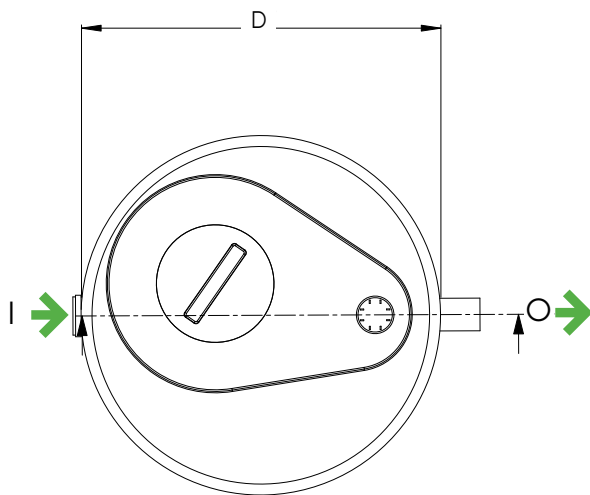

Item	Code	User (E.I.)	Capacity (liters)	D (cm)	H (cm)	H _i (cm)	Ø _i and Ø _o (mm)
Type 500	IS7001B	5	500	80	120	102	100
Type 1000	IS7002B	10	1.000	110	122	95	100
Type 1500	IS7003B	15	1.500	120	140	115	125
Type 2000	IS7004B	25	2.000	120	195	170	140
Type 3000	IS7005B	35	3.000	147	200	170	140
Type 4000	IS7006B	50	4.000	147	245	215	160
Type 6000	IS7008B	70	6.000	215	220	173	160
Type 8000	IS7009B	80	8.000	215	270	217	160
Type 10000	IS7010B	100	10.000	215	305	251	200

PRODUCT DESCRIPTION

System based on the use of a polyethylene Package aerobic percolating filter, suitable for treating domestic and commercial wastewater. The complete system setup comprises a one-piece polyethylene grease trap for the pre-treatment of greywater; an imhoff septic tank for the pre-treatment of sewage; the aerobic percolating filter for sewage treatment; and a second imhoff septic tank for secondary settling so that the resulting effluent can be discharged to a suitable final destination.

GREASE TRAP

Designed to trap grease, oils and other floating material that can interfere with the correct performance of the subsequent biological process.

IMHOFF TANK

Responsible for primary reduction of the organic loading of the wastewater, and also providing for digestion of the sludge produced.

AEROBIC PERCOLATING FILTER

Suitably filled with polypropylene media featuring a high specific surface area to encourage the growth of the bacterial population responsible for purifying the wastewater, so that the resulting effluent can be discharged to a suitable final destination.

SECONDARY IMHOFF TANK

For digestion of the sludge produced.

INSTALLATION (p. 74)

PIT

Dig a suitably sized pit. Line the bottom of the pit with a 10 cm thick layer of sand or other aggregate with a particle size ranging from 0 to 5 mm. Dampen the sand.

CONNECTIONS

Connect the secondary imhoff tank outlet to an inspection chamber with a PVC pipe. Connect the aerobic percolating filter outlet to the secondary imhoff tank inlet with a PVC pipe.

Connect the grease trap and imhoff tank outlets to the aerobic percolating filter inlet with a PVC pipe. Connect the greywater line to the grease trap and sewage line to the imhoff tank with polypropylene or PVC pipes.

FILLING

Fill the units with clean water to start the biological process properly.

BACKFILLING AND FINISHING

Backfill around the sides with damp sand or other aggregate sized between 0 and 5 mm. Top the backfill with a max. 40 cm thick layer of topsoil after first producing a 5 cm thick lightweight concrete slab, locating inspection chambers so that they are lined up with the screw on covers. If the area is subject to vehicular traffic, produce a reinforced concrete slab.

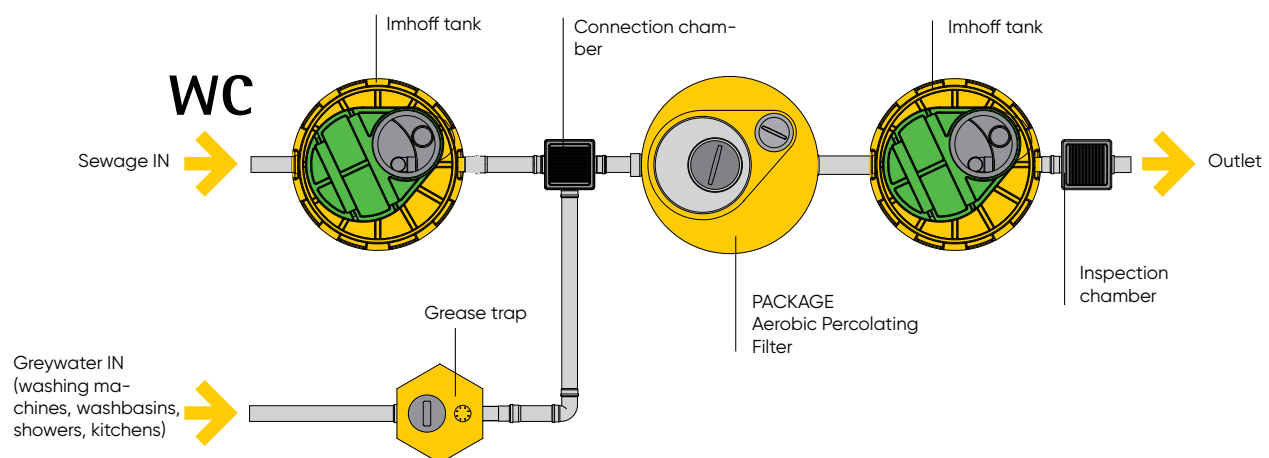

Wastewater treatment units, (subsurface-flow reed bed systems)



Subsurface-flow reed bed systems are used for domestic and commercial wastewater that does not run into the public sewer or a surface water body.

Wastewater entering the system is distributed inside a number of beds, each containing a suitable number of plants. The treatment process exploits the soil's evapotranspiration properties, both directly and through the plants, and the absorption of the wastewater's organic content by the plants' own root system. The only water leaving the system is rainwater, which only occurs when there is a storm. Said water is nonetheless deemed to be sufficiently diluted and hence can be discharged through the system's overflow pipe or returned upstream by a suitable recirculation pump station, thus ensuring that absolutely no wastewater is allowed to leave the system. These systems can be complemented with pre-treatments to improve overall treatment efficiency, depending on the properties of the influent.

Subsurface flow systems are particularly suitable for small and medium sized communities as they bring the following

advantages:

- treatment process simplified;
- very high effluent quality standard achieved and problem of effluent discharge eliminated;
- simple to run and maintain;
- zero electricity consumption;
- option of extending the system over time without hefty investments, producing a system that is extremely easy to run.⁵⁴

COUNTRY

Reed bed systems



PRODUCT CATEGORY

Subsurface-flow reed bed system

PRODUCT NAME

COUNTRY

APPLICATION

Treatment of domestic and commercial wastewater for discharge onto land

NO. OF USERS SERVED

2 - 100 E.I.

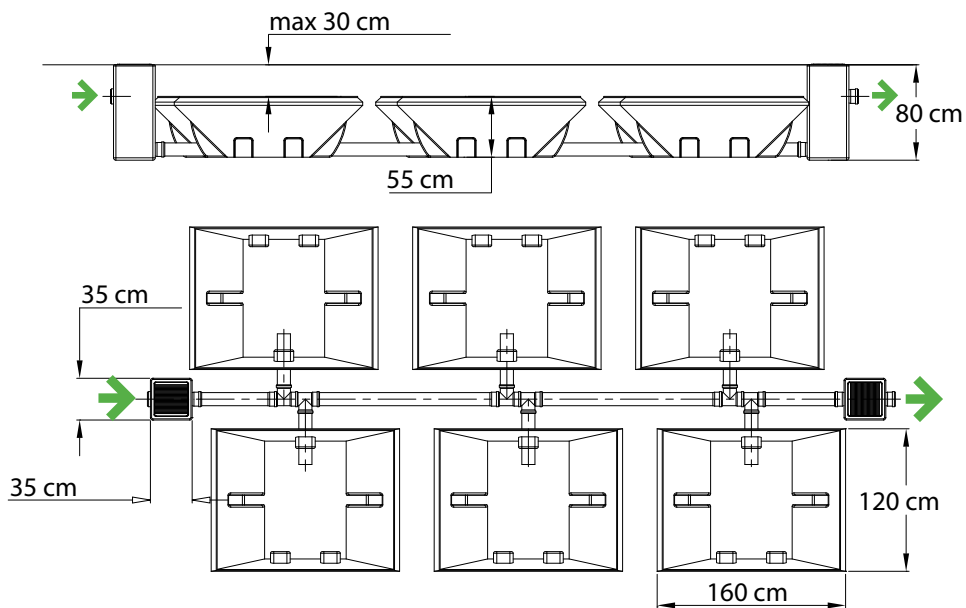

Code	User (E.I.)
IS08112	2
IS08114	4
IS08116	6
IS08118	8
IS81110	10
IS81112	12
IS81114	14
IS81116	16
IS81118	18
IS81120	20

N.B. For bigger surfaces please refer to our technical service.

The unit comes provided with:

- 2 polyethylene chambers (35,5x35,5x80 cm) complete with cover,
- polyethylene absorbent trays (120x160x55 cm),
- non-woven fabric,
- PP pipes,
- connectors and gaskets

PRODUCT DESCRIPTION

The Country subsurface-flow system is particularly suitable for small and medium-sized communities; it exploits the soil's evapotranspiration properties, both directly and through the plants, and the absorption of the wastewater's organic content by the plants. It is popular to complete the system with the polyethylene grease trap for the pre-treatment of greywater and polyethylene imhoff tank for the pre-treatment of sewage.

IMHOFF TANK in polyethylene on sewage line.

GREASE TRAP in polyethylene on greywater line.

INITIAL CHAMBER in polyethylene W/L = 35.5 cm H = 80 cm with PVC cover, into which water flows from the units upstream.

REED BEDS

in polyethylene; watertight, truncated pyramid shaped; width = 120 cm, length = 160 cm, height = 55 cm; featuring nonwoven fabric, polypropylene seal and fittings; each reed bed has a 2 m² surface area.

POLYPROPYLENE PIPING with watertight seals, 110 mm Ø, for connection between beds.

END CHAMBER in polyethylene W/L = 35.5 cm H = 80 cm with PVC cover, fitted with overflow pipe for discharging rainwater, where necessary.

INSTALLATION

PIT

Install the imhoff tank and grease trap following the instructions given on the relevant technical data sheets. Dig a perfectly horizontal pit large enough to take the beds; line the bottom with a layer of sand or other aggregate with a particle size ranging from 0 to 5 mm and then place the beds on top.

The base of the beds must lie at a depth of 80-120 cm.

CONNECTION

A filling/inspection chamber will be installed at the point where the pipes leaving the imhoff tank and grease trap are connected, and an identical chamber will be installed at the outlet of the last reed bed.

FILLING

Install the imhoff tank and grease trap, making sure you fill both to the top with water. Fill the beds with a layer of pebbles (10-15 cm) followed by a layer of gravel (30 cm) and top with topsoil for a max. depth of 50 cm.

BACKFILLING AND FINISHING

Backfill with damp sand or other aggregate with a particle size ranging from 0 to 5 mm until you are level with the top edge of the bed, then finish backfilling with topsoil.

USE

START-UP

Make sure that installation is carried out as prescribed in a professional manner. Plant evergreen vegetation with a sufficiently developed root system (a list is provided).

CHECKING AND MAINTENANCE

To keep the system running at peak efficiency, the grease trap must be cleaned at regular intervals and sludge that has built up inside the imhoff tank must be emptied on a regular basis.

COMPLIANCE WITH STANDARD

91/271 CE

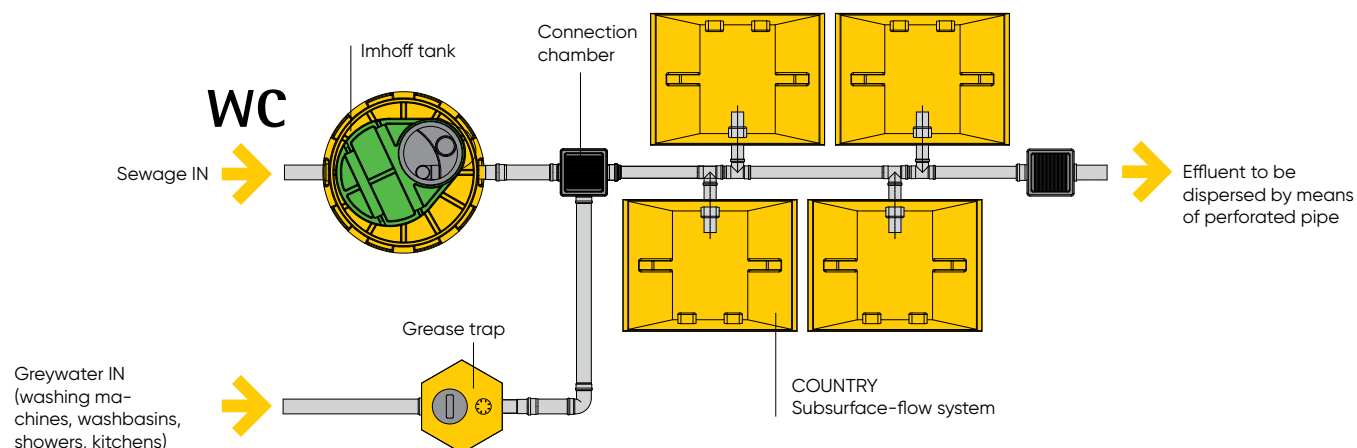

COUNTRY MAXI

Subsurface-flow reed bed systems

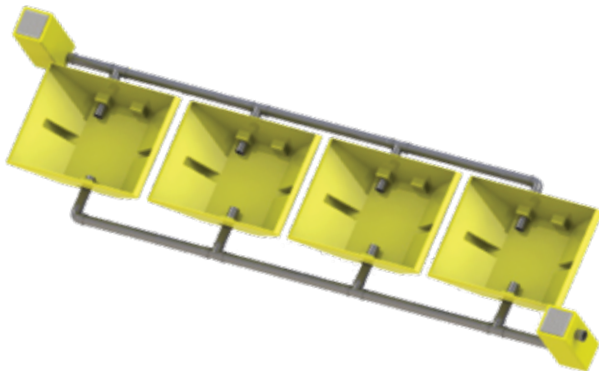

PRODUCT CATEGORY

Subsurface-flow reed bed system

PRODUCT NAME

COUNTRY MAXI

APPLICATION

Treatment of domestic and commercial wastewater for discharge onto land

NO. OF USERS SERVED

2 - 100 E.I.

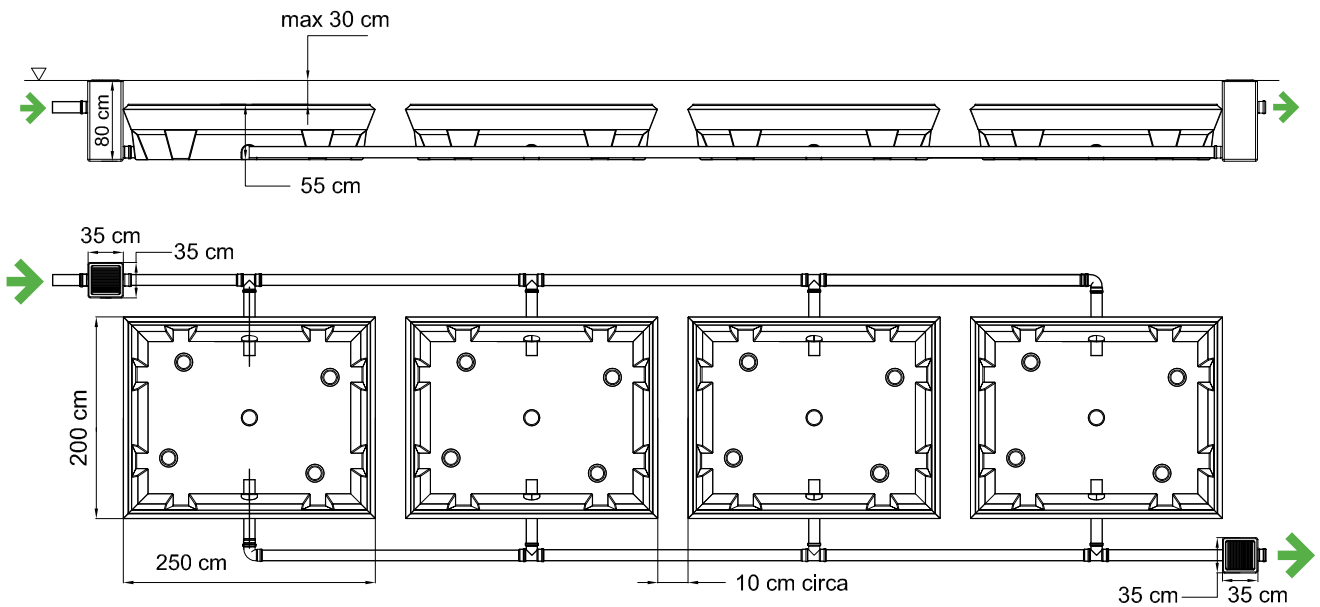

Code	User (E.I.)
IS831A2	2
IS831A4	4
IS831A6	6
IS831A8	8
IS83110	10
IS83112	12
IS83114	14
IS83116	16
IS83118	18
IS83120	20

N.B. For bigger surfaces please refer to our technical service.

The unit comes provided with:

- 2 polyethylene chambers (35,5x35,5x80 cm) complete with cover,
- polyethylene absorbent trays (200x250x55 cm),
- non-woven fabric,
- PP pipes (Ø 110 mm)
- connectors and gaskets

ISEA warrant that effluent quality meets the standards indicated in Italian legislative decree n°152/06.

PRODUCT DESCRIPTION

The Country Maxi subsurface-flow system is to be used where a 4m² surface area is required per P.E.; where the required surface area is less than 5 m² per P.E., Country Maxi is an excellent solution for wastewater generated by a medium number of users, allowing for significant space savings and improved distribution of wastewater within the beds. It is popular to complete the system with the polyethylene grease trap for the pre-treatment of greywater and polyethylene imhoff septic tank for the pre-treatment of sewage.

IMHOFF TANK in polyethylene on sewage line.

GREASE TRAP in polyethylene on greywater line.

INITIAL CHAMBER in polyethylene W/L = 35.5 cm H = 80 cm with PVC cover, into which water flows from the units upstream.

REED BEDS in polyethylene; watertight, truncated pyramid shaped; 5 m² surface area, W/L = 200 cm, height = 55 cm; featuring nonwoven fabric, polypropylene seal and fittings.

POLYPROPYLENE PIPING with watertight seals, 110 mm Ø, for connection between beds.

END CHAMBER in polyethylene W/L = 35.5 cm H = 80 cm with PVC cover, fitted with overflow pipe for discharging rainwater, where necessary.

INSTALLATION

PIT

Install the imhoff tank and grease trap following the instructions given on the relevant technical data sheets. Dig a perfectly horizontal pit large enough to take the beds; line the bottom with a layer of sand or other aggregate with a particle size ranging from 0 to 5 mm and then place the beds on top.

The base of the beds must lie at a depth of 80-120 cm.

CONNECTIONS

A filling/inspection chamber will be installed at the point where the pipes leaving the imhoff tank and grease trap are connected, and an identical chamber will be installed at the outlet of the last reed bed.

FILLING

Install the imhoff tank and grease trap, making sure you fill both to the top with water. Fill the beds with a layer of pebbles (10-15 cm) followed by a layer of gravel (30 cm) and top with topsoil for a max. depth of 50 cm.

BACKFILLING AND FINISHING

Backfill with damp sand or other aggregate with a particle size ranging from 0 to 5 mm until you are level with the top edge of the bed, then finish backfilling with topsoil.

USE

START-UP

Make sure that installation is carried out as prescribed in a professional manner. Plant evergreen vegetation with a sufficiently developed root system (a list is provided).

CHECKING AND MAINTENANCE

To keep the system running at peak efficiency, the grease trap must be cleaned at regular intervals and sludge that has built up inside the imhoff tank must be emptied on a regular basis.

COMPLIANCE WITH STANDARD

91/271 CE

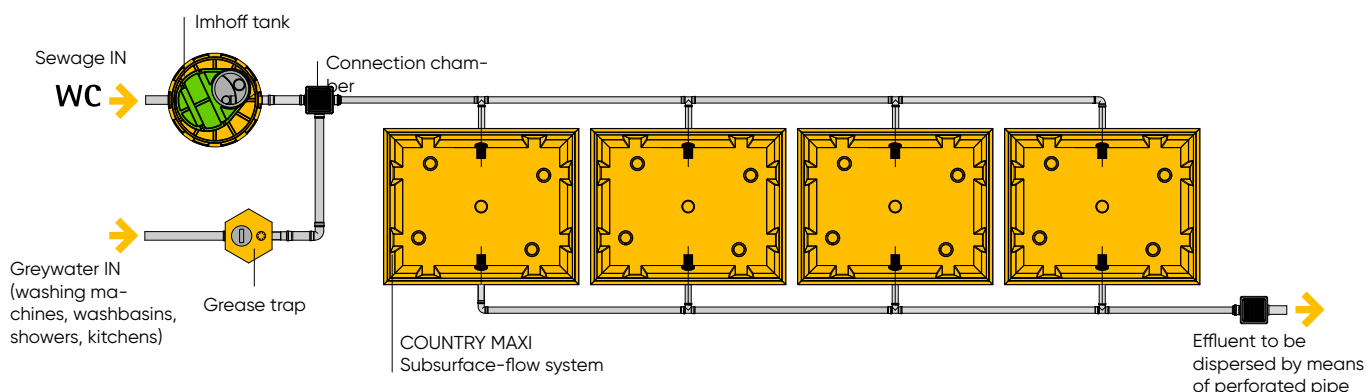

COUNTRY VERTICAL FLOW

Subsurface-flow reed bed systems

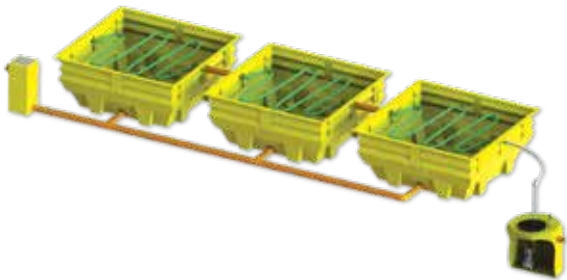

PRODUCT CATEGORY

Subsurface-flow reed bed system

PRODUCT NAME

COUNTRY VERTICAL FLOW

APPLICATION

Treatment of domestic and commercial wastewater for discharge onto land

NO. OF USERS SERVED

2 - 100 E.I.

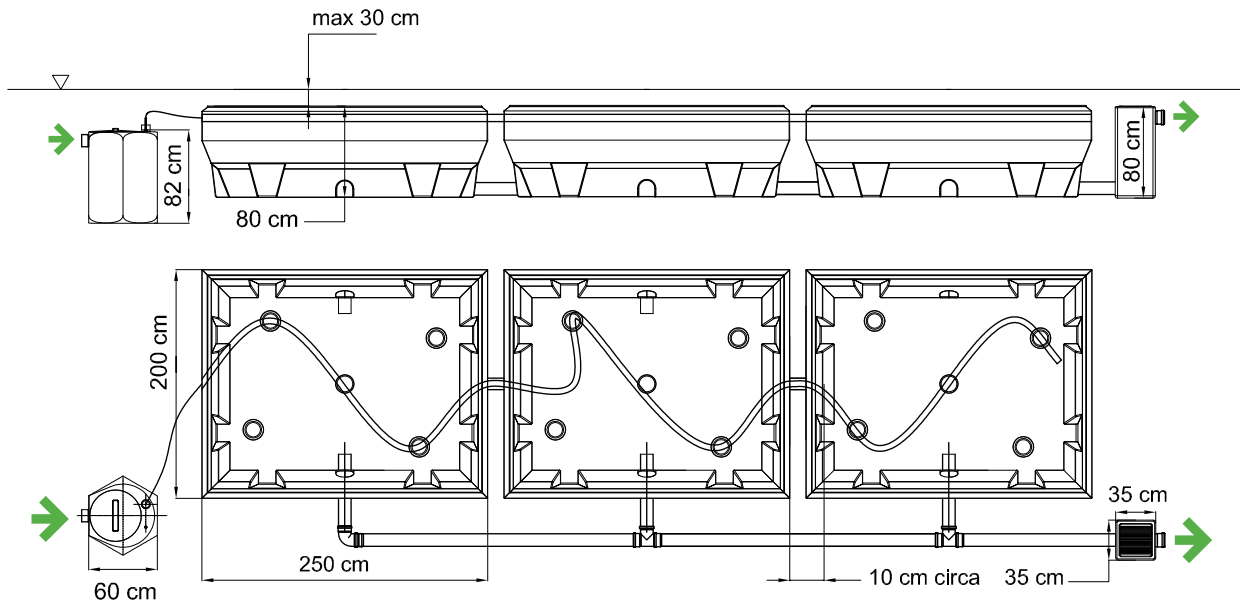

Code	User (E.I.)	Users (E.I.)
IS08211	1	2
IS08212	2	4
IS08213	3	6
IS08214	4-5	8
IS08215	6	10
IS08216	7	12
IS08217	8	14
IS08218	9-10	16
IS82109	11	18
IS82110	12	20
IS82111	13	22
IS82112	14-15	24
IS82113	16	26
IS82114	17	28
IS82115	18	30
IS82116	19-20	32

The unit comes provided with:

- 1 polyethylene chambers (35,5x35,5x80 cm) complete with cover,
- polyethylene absorbent trays (200x250x55 cm),
- non-woven fabric,
- PP pipes (Ø 110 mm)
- connectors and gaskets
- Lifting pump 250 litres complete of submersible pump (0,55 kW - 220 V) with floater

PRODUCT DESCRIPTION

The Country Vertical subsurface-flow system in the complete version involves wastewater pre-treatment by means of an Imhoff septic tank for sewage and grease trap for greywater; a subsurface vertical flow zone with a dedicated 5 m² surface area per reed bed; and a recirculation pump station downstream to return water that has not evaporated to the head of the system by means of perforated piping, allowing the water to percolate vertically through the soil held in the beds.

The Country Verticale subsurface flow system comes complete with:

IMHOFF TANK in polyethylene on sewage line.

GREASE TRAP in polyethylene on greywater line.

INITIAL CHAMBER

in polyethylene W/L = 35.5 cm H = 80 cm, with PVC cover, into which water flows from the units upstream.

REED BEDS in polyethylene; watertight, truncated pyramid shaped; 5 m² surface area each, W/L = 200 cm, H = 85 cm.

NONWOVEN FABRIC to be placed in each bed.

POLYPROPYLENE PIPING for connection between beds with watertight seals, Ø = 110 mm.

POLYETHYLENE PIPING for distribution.

FITTINGS AND SEALS RECIRCULATION PUMP STATION

one piece construction made from polyethylene; 500 litre capacity; complete with submersible motor-driven pump (0.55 kW - 220 V) with level regulator, ball valve and non-return valve on delivery line and overflow.

INSTALLATION

PIT

Install the Imhoff Tank and Grease Trap following the instructions given on the relevant technical data sheets. Dig a perfectly horizontal pit large enough to take the beds; line the bottom with a layer of sand or other aggregate with a particle size ranging from 0 to 5 mm and then place the beds on top. The base of the beds must lie at a depth of approx. 90-100 cm.

CONNECTIONS

A filling/inspection chamber will be installed at the point where the pipes leaving the Imhoff tank and grease trap are connected; the recirculation pump station will be installed at the outlet of the last reed bed, complete with final overflow.

FILLING

Install the Imhoff tank and grease trap, making sure you fill both to the top with water. Fill the beds with a layer of pebbles (15 cm) followed by a layer of gravel (30 cm), place the nonwoven fabric on top and finish with an approx. 40 cm thick layer of topsoil.

BACKFILLING AND FINISHING

Backfill with damp sand or other aggregate with a particle size ranging from 0 to 5 mm until you are level with the top edge of the bed, then finish backfilling with topsoil. Backfill around the sides of the recirculation pump station with lightweight concrete and prepare for reinforced concrete to be cast if the area is subject to vehicular traffic.

USE

ELECTRICAL CONNECTION

Connect the pump provided to the mains power line.

START-UP

Make sure that installation is carried out as prescribed in a professional manner. Plant evergreen vegetation with a sufficiently developed root system (a list is provided). You will also need to power the recirculation pump station by setting the switch on the panel to ON.

CHECKING AND MAINTENANCE

To keep the system running at peak efficiency, the grease trap must be cleaned at regular intervals and sludge that has built up inside the Imhoff tank must be emptied on a regular basis.

Check the recirculation pump station's electromechanical equipment at least once a year.

COMPLIANCE WITH STANDARD

91/271 CE

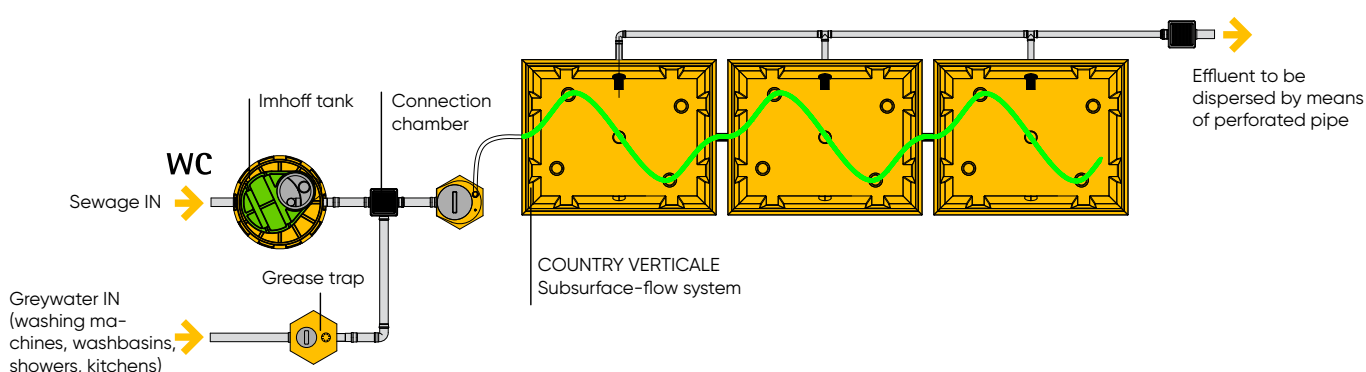

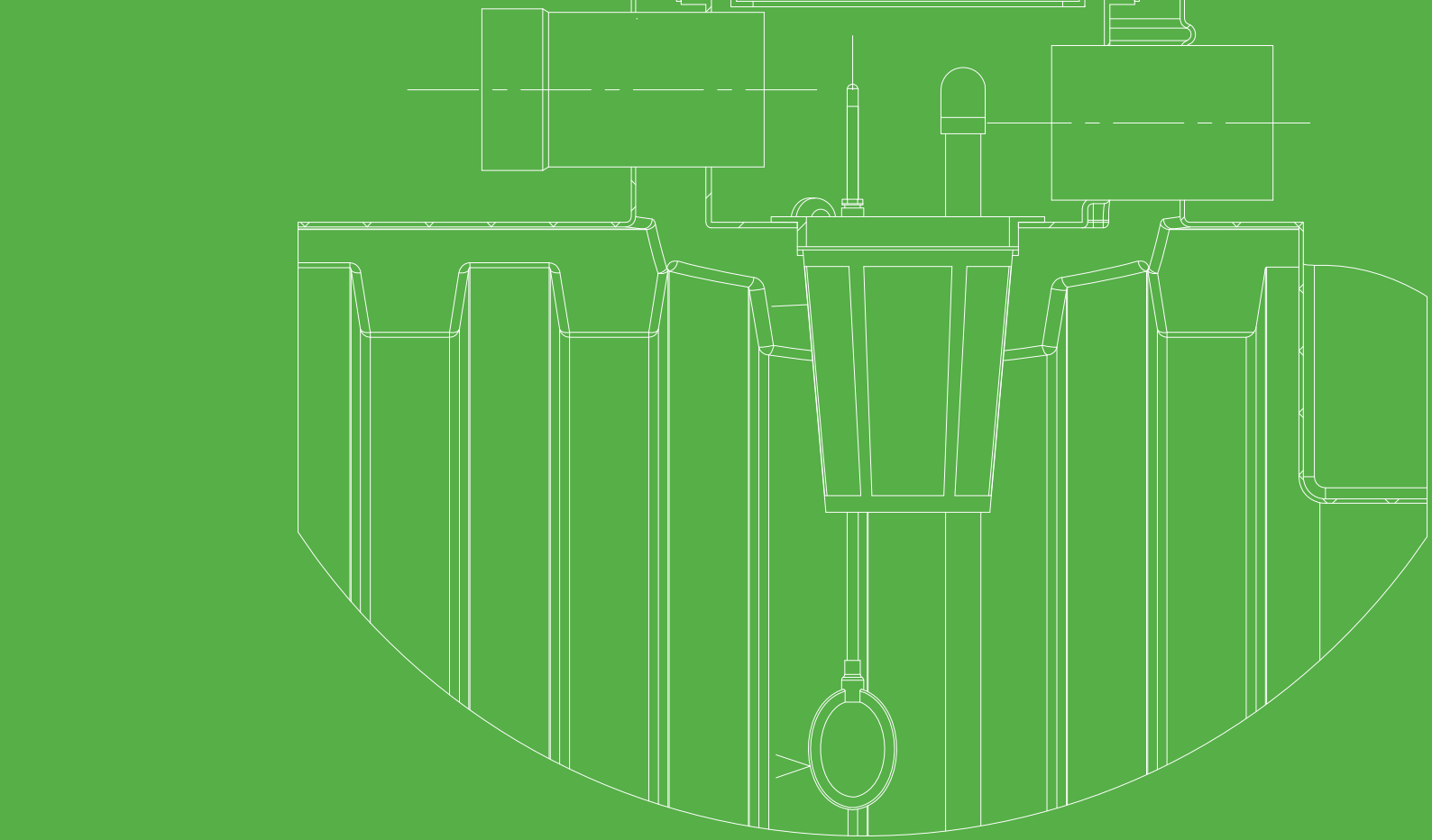

Water recovery



Water recovery systems enable the reuse of waters already treated by means of suitable engineering solutions.

Eco Box range make possible the irrigation of green areas not with mist but with the drop-by-drop system.

The process consists on the tertiary wastewater treatment, i.e. disinfection with a dose of sodium hypochlorite and filtration under pressure through a filter based on sand and carbon.

The installations are placed downstream from water treatment systems and contribute to make possible the reuse of wastewater, which, instead of being sent to the final receptor, thus removed, can serve to aforementioned applications.

Irriga products, from the other hand, are made to reuse rainwater from housing and assure an ideal water reserve for green spaces irrigation, car washing etc.

The rainwater is accumulated in a buried or external tank and distributed by an electro pump or through gravity forces. Thanks to this installation rainwater, instead of being wasted, is kept for domestic use mentioned above.

ECO BOX

Refinement systems



PRODUCT CATEGORY

Refinement system

PRODUCT NAME

ECO BOX

APPLICATION

Tertiary treatment system allowing reuse of wastewater

NO. OF USERS SERVED

Up to 200 E.I.

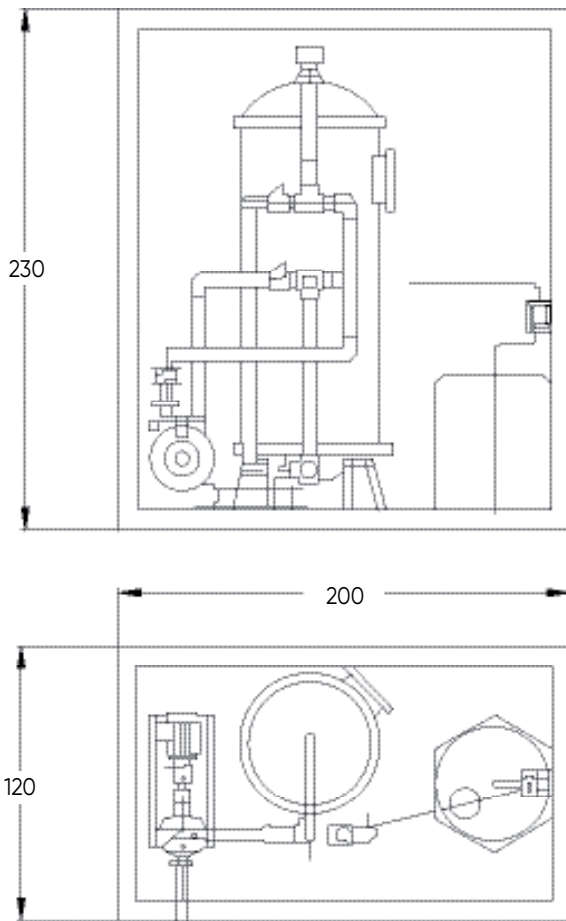

Disinfection and filtration

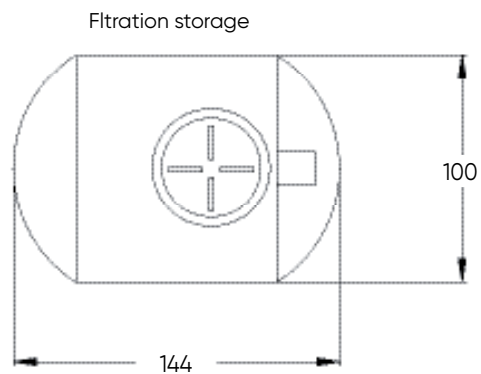
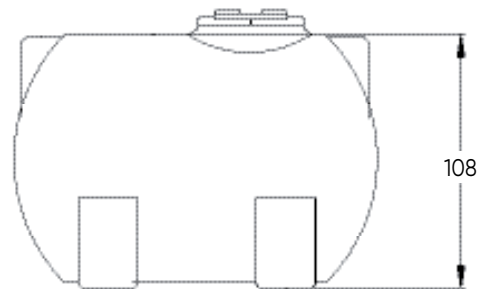

Filtration storage

Item	Code	Users (E.I.)	Storage			Disinfection and filtration			Filters		Voltage (V)	Power (kW)
			W (cm)	L (cm)	H (cm)	W (cm)	L (cm)	H (cm)	Sand and carbon	Q (m ³ /h)		
RAD1 220V	10101	until 50	100	144	108	120	200	230	sand and activated carbon	2	220	1
RAD2 380V	10102	51-100	137	220	145	120	200	230	sand and activated carbon	2	380	1
RAD3 380V	10103	101-150	137	220	145	120	200	230	sand and activated carbon	2	380	1
RAD4 380V	10104	151-200	174	215	180	120	200	230	sand and activated carbon	2	380	1

PRODUCT DESCRIPTION

The tertiary treatment system Eco Box allows the reuse of waters already treated by means of suitable treatment systems (activated sludge etc.)

The stages of the process are the following:

- Accumulation of purified effluent;
- Disinfection with a dose of sodium hypochlorite;
- Filtration under pressure through a filter based on active sand and carbon.

Water accumulated in Eco Box can be used for car washing, green areas irrigation etc. This water is not intended for consumption.

ACCUMULATION

Wastewater is stored in polyethylene tank, which serve also as a contact chamber in the disinfection stage.

DISINFECTION

Is initiated by a dose of sodium hypochlorite, introduced by a dosing electromagnetic pump, with regulated flow, featured with time delay option. The pump absorbs the disinfecting solution from the storage polyethylene tank and applies it automatically into the contact chamber.

FILTRATION

Filtration under pressure through the active sand and carbon filter, fitted with external self-priming, single or polyphasic pump, powered 0,75 KW. The pressure filter is featured with annual valves for secondary cleaning.

APPLIANCE CONTROL

The control of the appliances is done by an electric square, that measures on time controlled basis the functioning of dosing pump and self priming pump feeding the filter.

INSTALLATION (p. 75)

PIT

For the contact chamber please apply the general rules of underground placement, common for our products.

Dig a suitably sized pit. Line the bottom of the pit with a 10cm-thick layer of sand or other aggregate with a particle size ranging from 0 to 5 mm. Dampen the sand and level the surface on which the appliance will sit.

CONNECTIONS

The outlet of activated sludge system placed upstream from Eco Box should be connected to the inlet of contact chamber. Connect the absorbing pipe of the dosing pump to the storage tank with the chloral solution. Connect the outlet pipe of the dosing pump to the contact chamber. Place the pump on a horizontal surface and connect the outlet of pressure filter pump. Connect the outlet of the filter to final receptor.

BACKFILLING AND FINISHING

Backfill around the sides with damp sand or other aggregate sized between 0 and 5 mm until the top of the unit.

FINISHING

Proceed accordingly to the general rules of underground finishing. The dosing pump, auto booting pump and the filter have to be placed in a dry and breezed location.

START-UP

Make sure that installation is carried out as prescribed in a professional manner. Check operation of the pumps.

USE

CHECKING AND MAINTENANCE

At regular intervals, open the screw-on cover to make sure that there are no larger bodies that could cover the entrance to the storage tank. Verify periodically that the water in the outlet doesn't contain any suspended solids. Wash the filter regularly with clean water. At least once a year check the dosing pump and auto-booting feeding pump functioning. Check also the electric components of the square and the level of disinfecting solution.

COMPLIANCE WITH STANDARD

2006/42/CE - 2004/108/CE - 2006/95/CE

IRRIGA PLUS

Rainwater recovery



CATEGORIE PRODUIT

Rainwater recovery

PRODUCT CATEGORY

IRRIGA PLUS

APPLICATION

Rainwater recovery for diverse applications

CAPACITY

3.500 to 41.000 liters



Basket screen



Control box

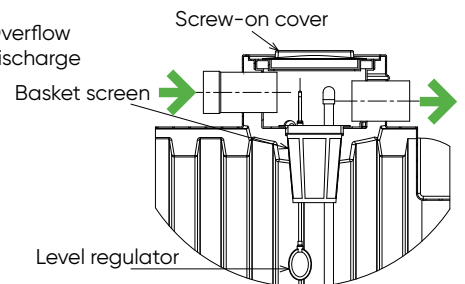
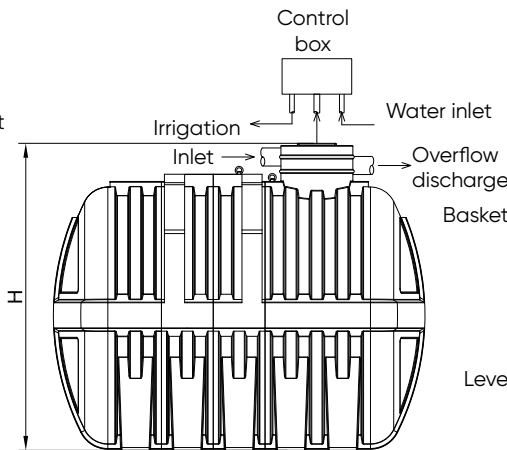
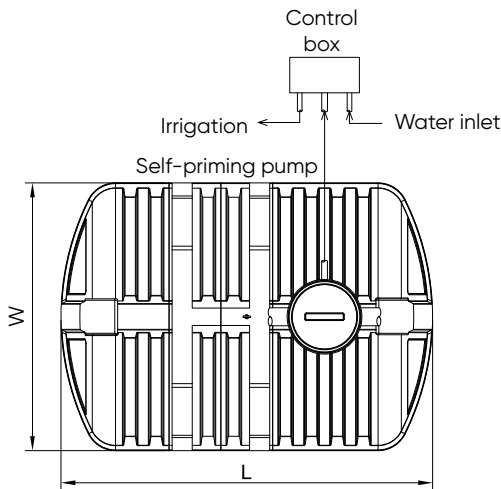

Item	Code	Capacity (litres)	Width W (cm)	Length L (cm)	Height H (cm)	Power (kW)	Voltage (V)	Cover (mm)
IRRIGA PLUS 3500	IS5001P	3.500	186	186	212	0,70	220	300
IRRIGA PLUS 6000	IS5002P	6.000	186	258	212	0,70	220	300
IRRIGA PLUS 9000	IS5013P	9.000	196	347	212	0,70	220	300
IRRIGA PLUS 12500	IS5004P	12.500	214	347	265	0,70	220	500x500
IRRIGA PLUS 16000	IS5005P	16.000	214	494	265	0,70	220	2x(500x500)
IRRIGA PLUS 21000	IS5006P	21.000	214	646	265	0,70	220	3x(500x500)
IRRIGA PLUS 26000	IS5007P	26.000	214	798	265	0,70	220	4x(500x500)
IRRIGA PLUS 31000	IS5008P	31.000	214	950	265	0,70	220	5x(500x500)
IRRIGA PLUS 36000	IS5009P	36.000	214	1.102	265	0,70	220	6x(500x500)
IRRIGA PLUS 41000	IS5010P	41.000	214	1.254	265	0,70	220	7x(500x500)

PRODUCT DESCRIPTION

Irriga Plus system is composed with following elements: 1 monobloc rotomoulded storage tank made of polyethylene featured with:

- inlet PVC pipe;
- by-pass PVC pipe;
- filter to catch leaves, dust, mould;
- absorbing pipe with well screen;
- self-priming external pump (power 0,37 kw) and electric control panel.

INSTALLATION (p. 75)

PIT

Dig a suitably sized pit. The bottom of the pit has to be flat and resistant enough to support the weight of the tank filled with water. Line the bottom of the pit with about 10 cm thick layer of sand. Place the tank in the middle of the pit leaving from each side a 20cm of free space.

BACKFILLING MODALITIES

Fill the tank until 2/3 of its volume. Backfill around the sides with damp sand proceeding per layers of 30 cm until the 2/3 of its high. Backfill the rest subsequently. Connect the compressor to the unit using the polypropylene pipe, which should be inserted in the relevant fittings, making sure the site where it is located is dry and positioned higher up than the wastewater outlet. Top the backfill with a 5cm thick lightweight concrete slab, or, if the area is subjected to vehicular traffic, produce a 25 cm thick reinforced concrete slab. In case there is no air ventilation in the

toilet, connect the unit's vent to a 100 mm PVC vent pipe, located at the roof capping level. The station can be fitted 25 cm and more underneath the topsoil.

SURFACE FINISHING

Lay a 5 cm thick lightweight concrete cover on top of the unit. Make sure to leave an inspection view nearby the cover of the tank. Preview the electric connections between the pump and the electric box. Finish with a reinforced concrete slab at least 25 cm thick if the area is subject to vehicular traffic

ELECTRICAL CONNECTION

Preview the electric connections between the pump and the electric box. In case if the groundwater level raise occasionally, consider backfilling the unit totally with concrete. In case of placing the unit on a hill, make sure to follow the instructions concerning specific installation.

USE

CHECKING AND MAINTENANCE

Once a year proceed an overall cleaning and check the stability of the tank.

Follow the maintenance steps presented here below:
empty the tank;
remove the residues if necessary;
clean the tank and accessories with water.

Every week or every second week during autumn check the screen and clean it if necessary.

COMPLIANCE WITH STANDARD

2006/42/CE - 2004/108/CE - 2006/95/CE



IRRIGA PLUS FLAT

Rainwater recovery



PRODUCT CATEGORY

Rainwater recovery

PRODUCT NAME

Irriga Plus Flat

APPLICATION

Rainwater recovery for diverse applications

CAPACITY

5.000 and 10.000 liters

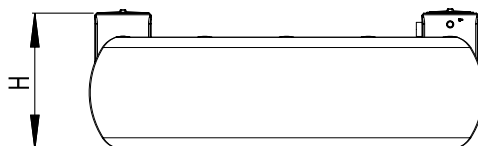
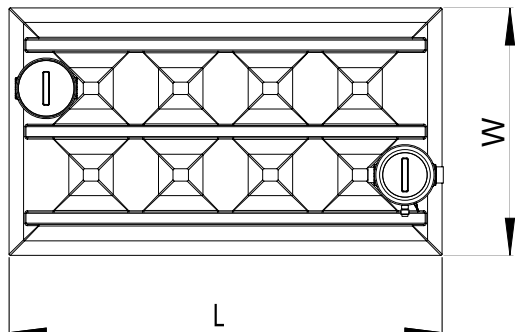

Item	Code	Capacity (liters)	Width W (cm)	Length L (cm)	Height H (cm)	Power (kW)	Voltage (V)	Cover (n° - mm)
IRRIGA PLUS FLAT 5000	IS5003P	5.000	200	350	120	0,70	220	2 - 400
IRRIGA PLUS FLAT 10000	IS5031P	10.000	420	350	120	0,70	220	4 - 400

Delivered with basket filter, electrical box, valve and pressure controller

PRODUCT DESCRIPTION

Irriga Plus Flat system is composed with following elements: 1 monobloc rotomoulded storage tank made of polyethylene featured with:

inlet PVC pipe;
by-pass PVC pipe;
filter to catch leaves, dust, mould;
absorbing pipe with well screen;
self-priming external pump (power 0,37 kw) and electric control panel.

INSTALLATION (p. 75)

PIT

Dig a suitably sized pit. The bottom of the pit has to be flat and resistant enough to support the weight of the tank filled with water. Line the bottom of the pit with about 10 cm thick layer of sand. Place the tank in the middle of the pit leaving from each side a 20cm of free space.

BACKFILLING MODALITIES

Fill the tank until 2/3 of its volume. Backfill around the sides with damp sand proceeding per layers of 30 cm until the 2/3 of its high. Backfill the rest subsequently.

Connect the compressor to the unit using the polypropylene pipe, which should be inserted in the relevant fittings, making sure the site where it is located is dry and positioned higher up than the wastewater outlet.

Top the backfill with a 5cm thick lightweight concrete slab, or, if the area is subjected to vehicular traffic, produce a 25 cm thick reinforced concrete slab.

In case there is no air ventilation in the toilet, connect the unit's vent to a 100 mm PVC vent pipe, located at the roof capping level. The station can be fitted 25 cm and more underneath the topsoil.

SURFACE FINISHING

Lay a 5 cm thick lightweight concrete cover on top of the unit. Make sure to leave an inspection view nearby the cover of the tank. Preview the electric connections between the pump and the electric box. Finish with a reinforced concrete slab at least 25 cm thick if the area is subject to vehicular traffic.

ELECTRICAL CONNECTION

Preview the electric connections between the pump and the electric box. In case if the groundwater level raise occasionally, consider backfilling the unit totally with concrete. In case of placing the unit on a hill, make sure to follow the instructions concerning specific installation.

USE

CHECKING AND MAINTENANCE

Once a year proceed an overall cleaning and check the stability of the tank.

Follow the maintenance steps presented here below:
empty the tank;
remove the residues if necessary;
clean the tank and accessories with water;

Every week or every second week during autumn check the screen and clean it if necessary.

COMPLIANCE WITH STANDARD

2006/42/CE - 2004/108/CE - 2006/95/CE

TANK

Horizontal cylindrical storage



PRODUCT CATEGORY

Storage for liquids

PRODUCT NAME

TANK

APPLICATION

Liquids storage

Item	Code	Capacity (liters)	W (cm)	L (cm)	H (cm)
TANK 500	IS02224	550	88	100	90
TANK 1000	IS02225	1.000	100	144	108
TANK 2000	IS02226	2.000	135	160	147
TANK 3000	IS02222	3.000	160	174	172
TANK 5000	IS02223	5.000	185	222	195
TANK 8000	IS02227	8.000	200	265	210
TANK 12500	IS02228	12.500	220	310	225

Above ground horizontal cylindrical storage.

FLAT



PRODUCT CATEGORY

Storage for liquids

PRODUCT NAME

FLAT

APPLICATION

Liquids storage

Item	Code	Capacity (liters)	W (cm)	L (cm)	H (cm)
FLAT	IS02250	5.000	200	350	120

Underground flat storage.

TANK-R

Horizontal cylindrical ribbed under-ground storage



PRODUCT CATEGORY

Storage for liquids

PRODUCT NAME

TANK-R

APPLICATION

Liquids storage

Item	Code	Capacity (liters)	W (cm)	L (cm)	H (cm)
TANK 3000 R	ISO2230	3.000	140	245	173
TANK 4000 R	ISO2231	4.000	186	186	212
TANK 5000 R	ISO2232	5.000	190	245	220
TANK 6000 R	ISO2221	6.000	186	258	212

Horizontal cylindrical ribbed underground container.

MAXITANK



PRODUCT CATEGORY

Storage for liquids

PRODUCT NAME

MAXITANK

APPLICATION

Liquids storage

Item	Code	Capacity (liters)	W (cm)	L (cm)	H (cm)
TANK 9000 M	ISO2233	9000	196	347	212
TANK 12500 M	ISO2400	12.500	214	347	228
TANK 16000 M	ISO2401	16.000	214	494	228
TANK 21000 M	ISO2402	21.000	214	646	228
TANK 26000 M	ISO2403	26.000	214	798	228
TANK 31000 M	ISO2404	31.000	214	950	228
TANK 36000 M	ISO2405	36.000	214	1102	228
TANK 41000 M	ISO2406	41.000	214	1254	228

Horizontal cylindrical ribbed underground container.

STATIC SCREEN

Accessories



PRODUCT CATEGORY

Accessories

PRODUCT NAME

STATIC SCREEN

APPLICATION

Retaining of gross solids

CAPACITY

500 and 1000 liters

Item	Code	Capacity (l)	WxL (cm)	H (cm)
Type 500	IS03501	480	80x86	82,5
Type 1000	IS03502	850	100x106	102,0

PRODUCT DESCRIPTION

Polyethylene static screen, complete with central cover with seal for inspection and maintenance, side supports to accommodate screen, stainless steel combs. The unit comes complete with PVC inlet and outlet pipe sections $\varnothing = 125$ mm.

INSTALLATION

PIT

Dig a suitably sized pit. Line the bottom of the pit with a 10 cm thick layer of sand or other aggregate with a particle size ranging from 0 to 5 mm. Dampen the sand and level the surface on which the unit will sit before lowering it inside.

CONNECTIONS

Connect the Static Screen outlet to an inspection chamber with a PVC pipe. Connect the effluent flow tube to the static screen inlet with a suitably sized connector.

FILLING

Fill the Static Screen unit with clean water to start the screening process properly.

BACKFILLING AND FINISHING

Backfill around the sides with damp sand or other aggregate with a particle size ranging from 0 to 5 mm. Lay a 5 cm thick lightweight concrete cover on top of the unit, or finish with a 25 cm thick reinforced concrete slab if the area is subjected to vehicular traffic, making sure a suitable inspection chamber is installed for the unit.

USE

START-UP

Make sure that installation is carried out as prescribed in a professional manner. Activate the flow to check the hydraulic work.

CHECKING AND MAINTENANCE

At regular intervals, open the screw-on cover to make sure that there are no larger bodies that could cover the entrance to the storage tank. Verify periodically that the water in the outlet doesn't contain any suspended solids. Remove sand and inert matter settled inside the grit separator on a regular basis. When removing pollutant material, clean the filtering equipment with a water blaster.

SPLITTER BOX

Accessories



PRODUCT CATEGORY

Accessories

PRODUCT NAME

SPLITTER BOX

CAPACITY

500 and 1000 liters

Item	Code	Capacity (l)	WxL (cm)	H (cm)
RS 500	IS00950	500	80x86	82,5
RS 1000	IS00952	1.000	120	120

Polyethylene chamber featuring PVC inlet, outlet and bypass pipe sections located at appropriate heights so as to achieve the desired separation of influent.

The heights of the PVC pipe sections vary depending on the influent flow to be controlled.

RISER

Accessories



PRODUCT CATEGORY

Accessories

PRODUCT NAME

RISER

APPLICATION

Complement to the water treatment installations

Item	Code	W (cm)	L (cm)	H (cm)
SPLITTER BOX SUPERPLUS S.1-S.2-S.3 OTTO-PE 015-030	IS00193	56	56	40
SPLITTER BOX SUPERPLUS S.4-S.5 OTTO-PE 045-060	IS00194	66	66	40

Polyethylene riser suitable for foot traffic for Super Plus and Otto PE inspection covers, comes in one height (40 cm).

Provision has been made for the riser to be cut down to a height of 20 or 30 cm where required.

Close with the Super Plus or Otto PE unit's own cover.

INSTALLATION

UNDERGROUND INSTALLATION PROCEDURE

For units used in systems that remain filled (with water the whole time)

ACTIVATED SLUDGE SYSTEMS

Super Plus, Super Plus Mix, Compact, Poli 1, Poli Maxi

SETTLING TANKS

FAMILY, ELLIPTIC TYPE PC,

OIL TRAPS AND GREASE TRAP

HT-Otto-PE - Family-PC-Public

IMHOFF TANKS

BIO TOP, BIO TOP MAXI

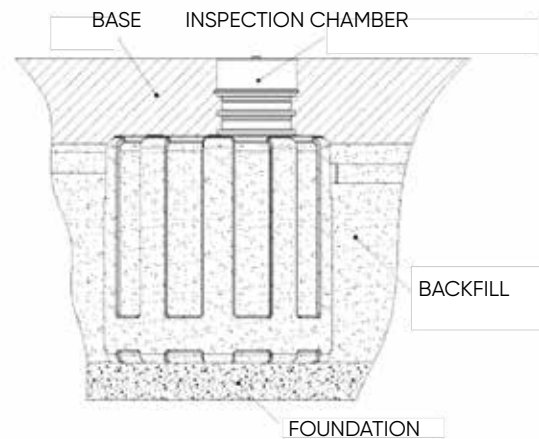

Before starting the underground installation procedure, check that the units are not damaged in any way.

- Dig a pit large enough to house the unit plus an extra 20 cm on each side.
- Prepare a surface to rest the unit on, lining the bottom of the pit with a 10cm-thick layer of packed-down damp sand or other aggregate with a particle size ranging from 0 to 5 mm. Level the surface on which the units will sit before lowering them inside.
- Place the units in the middle of the pit, making sure there is at least 20 cm of clearance all the way round (before performing any lifting operation, make sure that there is no water inside the units and that the lifting equipment is strong enough to take the weight of the units).
- Fill the units to 1/3 of their height and perform the first stage of backfilling, using damp sand to fill the pit up to the level of the water.
- Make whatever holes are required in the container and connect the inlet and outlet pipes, taking care to get the piping gradient right.
- Gradually (2/3 – 3/3) fill the units with water and, in parallel, backfill with damp sand up to the level of the water, doing your best to spread the material out as much as possible, and then backfill around the sides to the top of the containers.
- Place the inspection chamber (where required, not provided by Isea) downstream from the units for connection to the end receptor and for wastewater control.
- Top the unit based on the type of surface finish required, following the instructions contained in the sections entitled "Foot traffic areas", "Vehicular traffic areas".

WARNING

If groundwater is present in the pit, or if the ground is on a gradient or near a slope, the unit must be backfilled around the sides with concrete and topped with a concrete slab; both backfill and slab must be perfectly watertight.

Note: it is recommended to use always the lightened concrete to backfill the unit.

FOOT TRAFFIC AREAS

(NO LOADS BEARING ON THE SURFACE)

If the difference in level between the ceiling of the unit and ground level is less than 20 cm, build the surface of the pit up to the level of the surrounding ground using topsoil.

If the difference in level is between 20 and 50 cm, prepare an expanded clay and concrete mixture, which must be blended together well and dampened to get a firm mixture, spreading an approx. 5cm-thick layer of the material directly over the unit. Next, build the surface of the pit up to the level of the surrounding ground using topsoil.

If the difference in level to be made up between the ceiling of the tank and ground level is greater than 50 cm, produce a load-bearing reinforced concrete slab, sized based on the loads deriving from the application (it must be at least as wide as the pit plus an extra 50 cm on each side).

VEHICULAR TRAFFIC AREAS

(LOADS BEARING ON THE SURFACE)

To make the tanks strong enough to take vehicular traffic, slabs will need to be produced with different properties depending on how deep the tank is buried and, whatever the case, they must be at least as large as the pit plus an extra 50 cm on each side.

If the difference in level is less than 50 cm, produce a concrete slab at least 25 cm thick, making sure you place 2 sheets of electrically welded mesh (6 mm diameter wire) underneath before casting. Start by casting an initial layer about 5 cm thick, wait for the material to set and then cast the next layer (whatever the case, you will need to check what loads the slab will be required to bear and size it accordingly).

If the difference in level is greater than 50 cm, produce a load-bearing slab sized based on the loads deriving from the application.

Fit the chamber with a cover designed to take vehicular traffic and be careful not to set said cover down on the unit's shaft until the concrete casting has set. (the pit plus an extra 50 cm on each side).

UNDERGROUND INSTALLATION PROCEDURE

For units used in systems that remain only temporarily filled (not whole time)

LIFTING STATIONS

Pratica Family, Pratica, Pratica Roto, Pratica Public

RAINWATER RECOVERY

Irriga, Irriga Flat

CONTAINERS

Horizontal and vertical containers

Before starting the underground installation procedure, check that the units are not damaged in any way.

- Dig a pit large enough to house the unit plus an extra 20 cm on each side.
- Prepare a surface to rest the unit on, lining the bottom of the pit with a 10cm-thick layer of packed-down damp sand or other aggregate with a particle size ranging from 0 to 5 mm. Level the surface on which the units will sit before lowering them inside.
- Place the units in the middle of the pit, making sure there is at least 20 cm of clearance all the way round (before performing any lifting operation, make sure that there is no water inside the units and that the lifting equipment is strong enough to take the weight of the units).
- Fill the units to 1/3 of their height and perform the first stage of backfilling, using concrete to fill the pit up to the level of the water (warning: do not cast concrete in a single point, instead do your best to spread the concrete evenly around the tanks).
- Make whatever holes are required in the container and connect the inlet and outlet pipes, taking care to get the piping gradient right.
- Gradually (2/3 – 3/3) fill the units with water and, in parallel, backfill with concrete up to the level of the water, doing your best to spread the material out as much as possible, and then backfill around the sides to the top of the containers.
- Place the inspection chamber (where required, not provided by Isea) downstream from the units for connection to the end receptor and for wastewater control.
Check that both the tanks and their connections are perfectly watertight.
- Top the unit based on the type of surface finish required, following the instructions contained in the sections entitled "Foot traffic areas" and "Vehicular traffic areas".

WARNING

If groundwater is present in the pit, or if the ground is on a gradient or near a slope, the unit must be backfilled around the sides with concrete and topped with a concrete slab; both backfill and slab must be perfectly watertight.

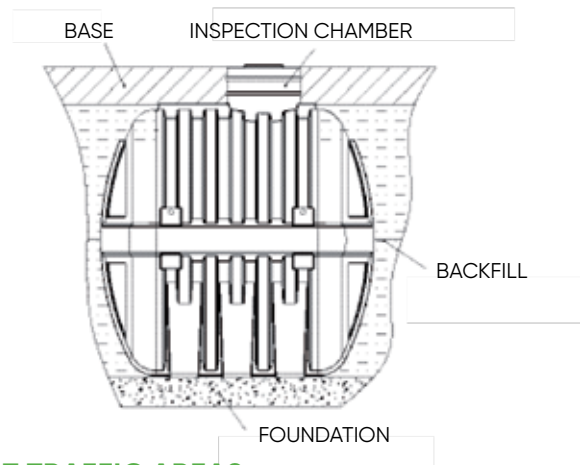

FOOT TRAFFIC AREAS

(NO LOADS BEARING ON THE SURFACE)

If the difference in level between the ceiling of the unit and ground level is less than 20 cm, build the surface of the pit up to the level of the surrounding ground using topsoil.

If the difference in level is between 20 and 50 cm, prepare an expanded clay and concrete mixture, which must be blended together well and dampened to get a firm mixture, spreading an approx. 5cm-thick layer of the material directly over the unit. Next, build the surface of the pit up to the level of the surrounding ground using topsoil.

If the difference in level to be made up between the ceiling of the tank and ground level is greater than 50 cm, produce a load-bearing reinforced concrete slab, sized based on the loads deriving from the application (it must be at least as wide as the pit plus an extra 50 cm on each side).

VEHICULAR TRAFFIC AREAS

(LOADS BEARING ON THE SURFACE)

To make the tanks strong enough to take vehicular traffic, slabs will need to be produced with different properties depending on how deep the tank is buried and, whatever the case, they must be at least as large as the pit plus an extra 50 cm on each side.

If the difference in level is less than 50 cm, produce a concrete slab at least 25 cm thick, making sure you place 2 sheets of electrically welded mesh (6 mm diameter wire) underneath before casting. Start by casting an initial layer about 5 cm thick, wait for the material to set and then cast the next layer (whatever the case, you will need to check what loads the slab will be required to bear and size it accordingly).

If the difference in level is greater than 50 cm, produce a load-bearing slab sized based on the loads deriving from the application.

Fit the chamber with a cover designed to take vehicular traffic and be careful not to set said cover down on the unit's shaft until the concrete casting has set. The pit plus an extra 50 cm on each side).

ISEA: field of study and realization



ISEA offers a complete range of wastewater treatment for urban and industrial sector, which contains:

activated fixed of free culture sludge stations type SBR with separated cisterns for small housing estates;

physical-chemical treatment;d

dissolved air flotation- ventilated oil traps - separators.

URBAN EFFLUENT TREATMENT

For smaller settlements ISEA offers solutions based on activated sludge systems with small charge, with fixed or suspended growth or SBR system.

The system for a number of users exceeding 500 EH are made of glass fiber reinforced polyester (GFRP).

TRADITIONAL ACTIVATED SLUDGE SYSTEM

SBR SYSTEM

FIXED GROWTH

INDUSTRIAL EFFLUENTS TREATMENT

ISEA has equally developed its savoir faire in terms of industrial wastewater, principally in food farming industry

EFFLUENTS COMING FROM AGRI-FOODSTUFF INDUSTRIES

EFFLUENTS COMING FROM CHEMICAL AND MECHANICAL INDUSTRIES

Activated sludge plants



DESIGN PARAMETERS

The essential problem for small entities is the importance of the peak flow compared to the average hourly flow of the plant. For 500 EH the coefficient is 4.

The coefficients, recommended by Water Agency and Technical Assistance Service for the Treatment Plants, guarantee a satisfying level of settling that prevents the sludge leakage into the outfall. Other important parameters to avoid sludge surplus are the volumetric loading of aeration tanks and the flow rate of filters.

The systems based on activated sludge with suspended growth have the aeration tank loading volume of 0,30 kgDBO5/m³. In case of fixed growth we use the support of a resistant PVC and the maximum volumetric loading: 0,35 kg DBO5/m³.

The treatment efficiency of this system is higher in the case of suspended growth, where the material chosen for the aeration tank allow the approximation of purifying bacteria to the material to be decomposed.

Seeking for an optimal relation between bacteria and substrate, certain constructors are prompt to chose higher volumetric loading and reduce volume of aeration tanks. This choice represents a risk, especially in the growth phase, where it can lead to an overproduction of sludge. Therefore the growth of sludge in the aeration tank can provoke a sealing of the support material, hardly reversible.

Furthermore, the overproduced sludge is less mineralised, which can be a cause of bad odours.

For this reason ISEA has limited the volumetric loading to 0,35 kg DBO5/m³, which helps to maintain conditions similar to those that we can find in the suspended growth system.

The filter flow rate correspond with relation between the outflow of the surface point do not exceed 0,60 m, And the pick flow complies with the coefficients defined above. Low flow rate guarantee a correct settling and prevent the sludge leakage.

The last important parameter concerning the dimension of the plant is the production of extra sludge volume.

Each system based on activated sludge generates a surplus of the sludge that has to be periodically evacuated from the system, otherwise the plant remains overcharged.

The oxygen delivered by the aeration system becomes insufficient to maintain the mass of sludge in aerobic conditions, which can cause odour problems.

The quantity of sludge surplus coming form activated sludge plants is of 0,9 - 1 kg SSMA per 1kg DB05

The sludge surplus treatment consists on increasing its concentration so as to diminish the volume that needs to be evacuated by a specialised company.

For the small units, it is recommended to use storage tank. Thanks to this appliance the sludge volume can be decreased from 8 -10 g/l (in a filter) to about 30 g/l, and the final volume of sludge surplus equals 1/3 of the input



volume. The sludge storage tank is indispensable both for the correct functioning of the activated sludge plant and for the savings on evacuations operations. Generally speaking, the storage tank is designed to stock the sludge surplus for 3 months approximately. For bigger plants, those exceeding 1000 EH, other solutions are established, such as gravity belt thickeners, centrifuges etc.

TREATMENT SYSTEMS

For smaller entities ISEA has designed the full plant equipment that includes: 1screen – 1 aeration chamber – 1 settling chamber – 1 sludge storage tank.

The oxygen, crucial in the decomposition process, is delivered through air supply pipe placed at the bottom of the aeration chamber.

The recirculation of the sludge and extraction of surplus are assured by a submersible pump. In some cases ISEA slightly modify this system, replacing the storage tank with a settling tank, placed uphill from the aeration chamber.

The settling tank has many advantages:

1. Enables settling of the effluent after screening in order to reduce loading of the pollutants to be treated. Consequently, the required aeration chamber volume is reduced.

2. Enables the storage of so a mixture of so called "primary" sludges, due to the settling of the raw effluent and the "secondary" ones, due to the biological process inside the activated sludge plant. Hence, it makes the storage tank no longer needed and doesn't require any other supplementary equipment. If the entities exceed 100 EH, they are made of glass fiber reinforced polyester (GFRP).

The principle of the treatment is the same as in the POLI system, but the 3 elements (aeration chamber- settling chamber- storage chamber) are collected in one single module, reaching even 12 m of length.

According to the number of users, one- or two-module plants are available.

The advantage of these plants is certainly the simplicity of assembly, but also the fact that they can be both, buried and placed on a surface platform.

EFFICIENCY AND WARRANTIES

ISEA warrants that the effluents quality meets the standards indicated in the European Directive 91/271 CE.

ISEA covers all electromechanical equipment with a 12-month warranty from the date of delivery.

Activated sludge system

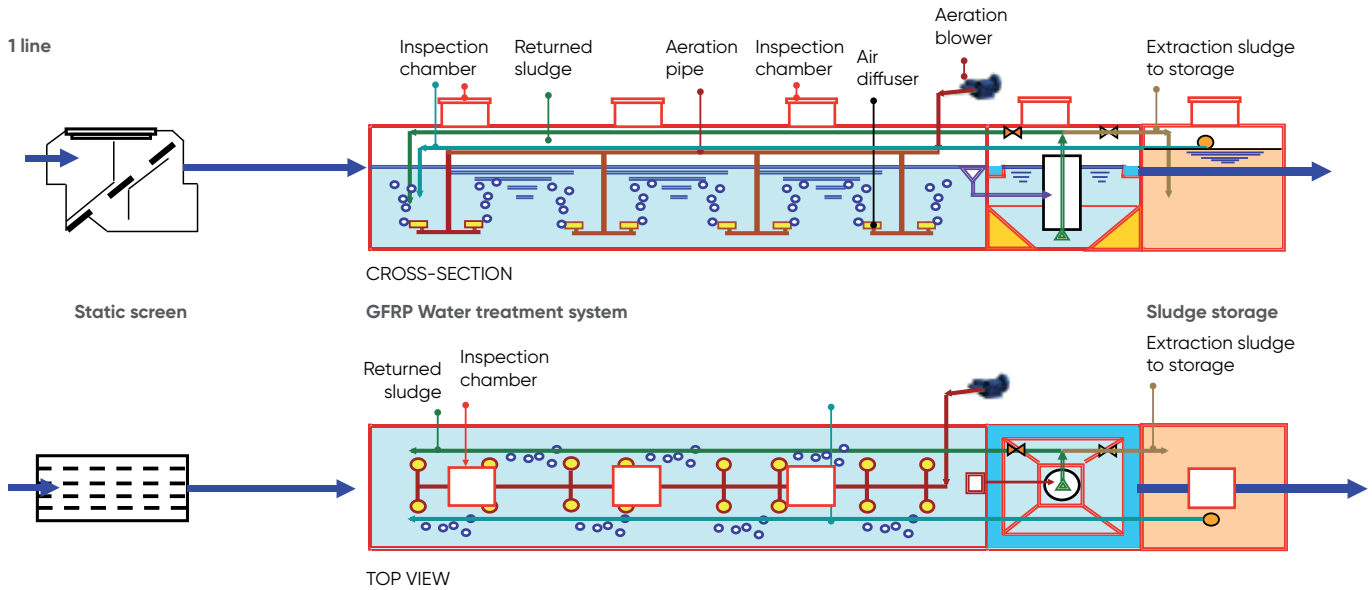

GRP SYSTEM

SFRP Activated sludge station with polyester storage tank - 1 line

no. of E.I.	Project features	Static Screen	Aeration chamber H water: 2,20 m H total: 2,40 m	Settling tank H water: 2,20 m H total: 2,40 m	Sludge storage H water: 2,20 m H total: 2,40 m
100 E.I.	Peak flow coefficient: 5 Volumetric load: 0,3	1,06 m x 1,00 m x 1,02 m	No. 1 Lenght: 4,17 m Unit volume: 20,00 m ³ Total volume: 20,00 m ³	No. 1 Lenght: 2,17 m Unit volume: 7,32 m ³ Total volume: 7,32 m ³	No. 1 Lenght: 1,73 m Unit volume: 9,56 m ³ Total volume: 9,56 m ³ Detention time: 60 jours
Total lenght 8,07 m - Total volume 36,87 m ³					
125 E.I.	Peak flow coefficient: 5 Volumetric load: 0,3	1,06 m x 1,00 m x 1,02 m	No. 1 Lenght: 5,21 m Unit volume: 25,00 m ³ Total volume: 25,00 m ³	No. 1 Lenght: 2,17 m Unit volume: 9,13 m ³ Total volume: 9,13 m ³	No. 1 Lenght: 2,16 m Unit volume: 11,94 m ³ Total volume: 11,94 m ³ Detention time: 60 jours
Total lenght 10,08 m - Total volume 46,07 m ³					
150 E.I.	Peak flow coefficient: 5 Volumetric load: 0,3	1,06 m x 1,00 m x 1,02 m	No. 1 Lenght: 6,25 m Unit volume: 30,00 m ³ Total volume: 30,00 m ³	No. 1 Lenght: 3,25 m Unit volume: 10,94 m ³ Total volume: 10,94 m ³	No. 1 Lenght: 1,95 m Unit volume: 10,75 m ³ Total volume: 10,75 m ³ Detention time: 60 jours
Total lenght 11,45 m - Total volume 51,69 m ³					

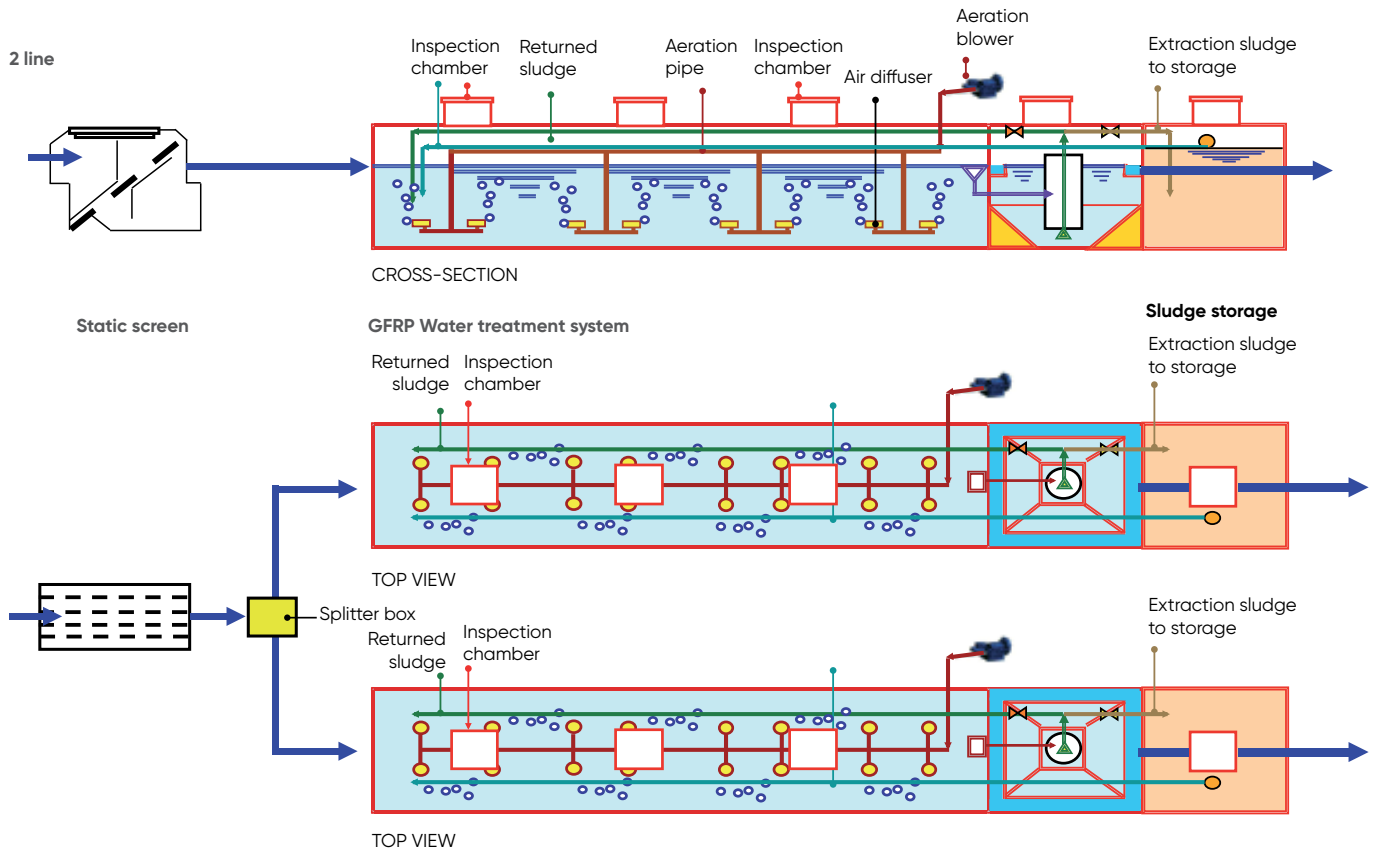

GRP Activated sludge station with polyester storage tank - 2 lines

no. of E.I.	Project features	Static Screen	Aeration chamber H water: 2,20 m H total: 2,40 m	Settling tank H water: 2,20 m H total: 2,40 m	Sludge storage H water: 2,20 m H total: 2,40 m
200 E.I.	Peak flow coefficient: 4 Volumetric load: 0,3	1,06 m x 1,00 m x 1,02 m	No. 2 Lenght: 4,17 m Unit volume: 20,00 m ³ Total volume: 40,00 m ³	No. 2 Lenght: 1,74 m Unit volume: 5,87 m ³ Total volume: 11,74 m ³	No. 2 Lenght: 1,30 m Unit volume: 7,17 m ³ Total volume: 14,34 m ³ Detention time: 6 45,00j
Total lenght 7,21 m - total volume 66,08 m ³					
250 E.I.	Peak flow coefficient: 4 Volumetric load: 0,3	1,06 m x 1,00 m x 1,02 m	Nombre: 1 Lenght: 5,21 m Unit volume: 25,00 m ³ Total volume: 50,00 m ³	No. 2 Lenght: 2,17 m Unit volume: 7,32 m ³ Total volume: 14,64 m ³	No. 2 Lenght: 1,62 m Unit volume: 8,96 m ³ Total volume: 17,92 m ³ Detention time: 6 45,00j
Total lenght 9,00 m - total volume 82,56 m ³					
275 E.I.	Peak flow coefficient: 4 Volumetric load: 0,3	1,06 m x 1,00 m x 1,02 m	No. 2 Lenght: 5,73 m Unit volume: 27,50 m ³ Total volume: 55,00 m ³	No. 2 Lenght: 2,39 m Unit volume: 8,04 m ³ Total volume: 16,08 m ³	No. 2 Lenght: 1,79 m Unit volume: 9,85 m ³ Total volume: 19,7 m ³ Detention time: 6 45,00j
Total lenght 9,91 m - total volume 90,78 m ³					
300 E.I.	Peak flow coefficient: 4 Volumetric load: 0,3	1,06 m x 1,00 m x 1,02 m	No. 2 Lenght: 6,25 m Unit volume: 30,00 m ³ Total volume: 60,00 m ³	No. 2 Lenght: 2,60 m Unit volume: 8,77 m ³ Total volume: 17,54 m ³	No. 2 Lenght: 1,95 m Unit volume: 10,75 m ³ Total volume: 21,50 m ³ Detention time: 6 45,00j
Total lenght 10,8 m - total volume 99,04 m ³					
350 E.I.	Peak flow coefficient: 4 Volumetric load: 0,3	1,06 m x 1,00 m x 1,02 m	No. 2 Lenght: 7,29 m Unit volume: 35,00 m ³ Total volume: 70,00 m ³	No. 2 Lenght: 3,04 m Unit volume: 10,21 m ³ Total volume: 20,42 m ³	No. 2 Lenght: 1,51 m Unit volume: 8,36 m ³ Total volume: 16,72 m ³ Detention time: 6 30,00j
Total lenght 11,84 m - total volume 107,14 m ³					

SBR Activated Sludge System



THE SBR

ISEA has equally dedicated one of its activated sludge systems to small urban settlements, offering them a compactness, by reducing the phase of separated settling: the SBR system (Sequencing Batch Reactor).

Both the biological treatment and settling are performing in one common chamber.

The treatment cycle consist on 3 phases:

Phase 1 Filling and aeration. (feeding with air through an air lift with a regular peak hourly flow driven by the PLC and probes; oxidation ensured by diffusers fitted with a PLC controlled compressor)

Phase 2 Settling.

Phase 3 Excess sludge discharge.

The system, thanks to elimination of a separated settling chamber permits to save space. Equally, it permits a better biomass settling, due to the alternation of anoxic and aerobic stages. Eventually, the biological processes are speeded up due to the increase in speed of substrate diffusion in sludge floc.

EFFICIENCY AND WARRANTIES

ISEA warrants that effluent quality meets the standards indicated in the European Directive 91/271/CE.

ISEA covers all electromechanical equipment with a 12-month warranty from the date of delivery.



BLOCK DIAGRAM

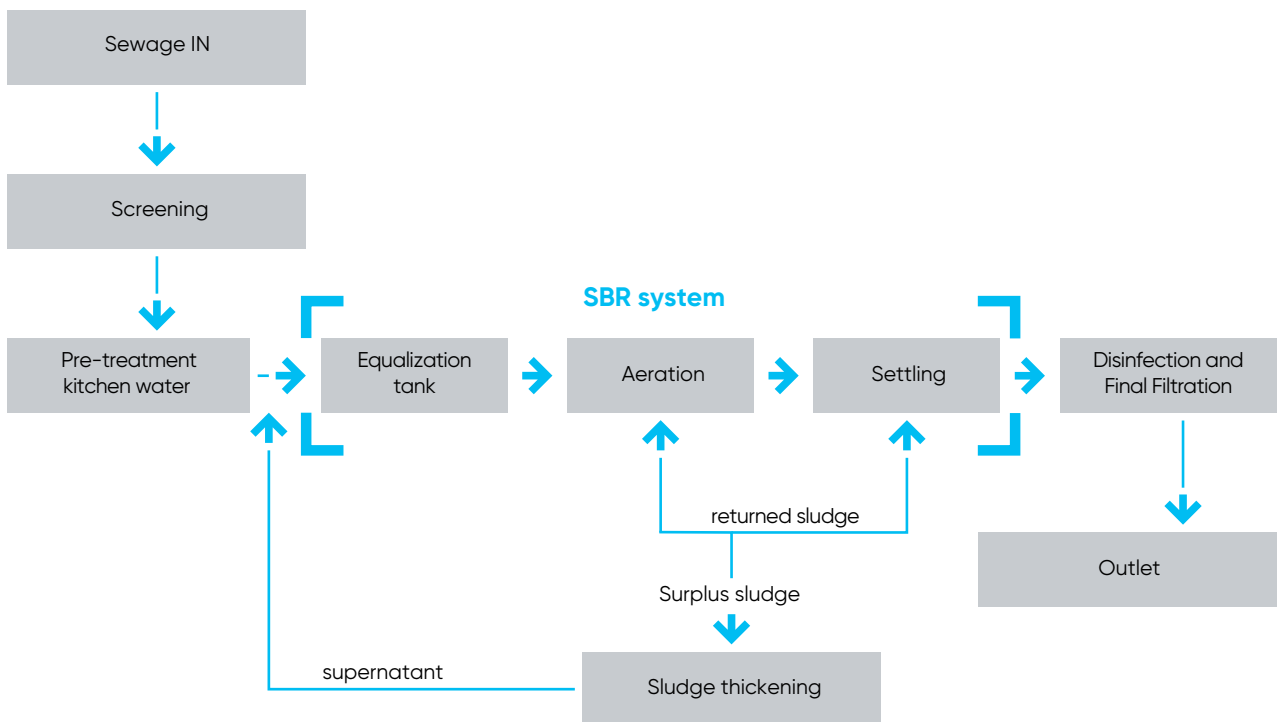

Fixed growth systems

SYSTEMS BASED ON FIXED GROWTH

ISEA has equally dedicated one of its activated sludge systems to small urban settlements offering them a solution based on fixed growth. The main idea is the combination of the biological processes of activated sludge and bacterial treatment through submerged membranes. The purifying efficacy of the system is superior to the one of the suspended growth, in terms of the input in the aeration chamber that allows the approximation of purifying bacteria to the material to be decomposed. As support, ISEA use a lining material from PVC, in configuration with crossed pipeline structure.

The material weight is 30 kg/m³ dry and 350 kg/m³ in optimal functioning conditions. The voids ratio is 97%.

The specific surface of material is 100 m²/m³ and is realised in a modular form with following dimensions: 1,17 m (L) x 0,60 m (W) x 0,60 m (H) whether the volume of 0,42 m³ per module.

The configuration with the pipeline with crossing structure has following advantages *

- an important volume of voids ensuring an efficient auto-cleaning
- maximal contact time between liquid and biomass increasing efficiency of the treatment
- High level of aeration and little loading loss
- Very high rigidity

The number of modules assembled is based on the ratio 30 g DBO₅/m² of specific surface. Seeking for an optimal relation between bacteria and substrate, certain constructors are prompt to chose higher volumetric loading and reduce volume of aeration tanks. This choice represents a risk, especially in the growth phase, where it can lead to an overproduction of sludge. Therefore the growth of sludge in the aeration tank can provoke a sealing of the support material, hardly reversible.

Furthermore, the overproduced sludges are less mineralised, which can be a cause of bad odours. In order to avoid these problem ISEA propose:

1. To install of an Imhoff tank that would lower the loading of pollutant to be treated by the plant based on fixed growth
 2. To chose a low volumetric loading, not exceeding 0,4 kg DBO₅/m³ of the aeration chamber.
- These dimensions helps to limit the overproduction sludge and avoid sealing of the support material.

EFFICIENCY AND WARRANTIES

ISEA warrants that effluent quality meets the standards indicated in the European Directive 91/271/CE.

ISEA covers all electromechanical equipment with a 12-month warranty from the date of delivery.

FIXED GROWTH OUTLINE DIAGRAM

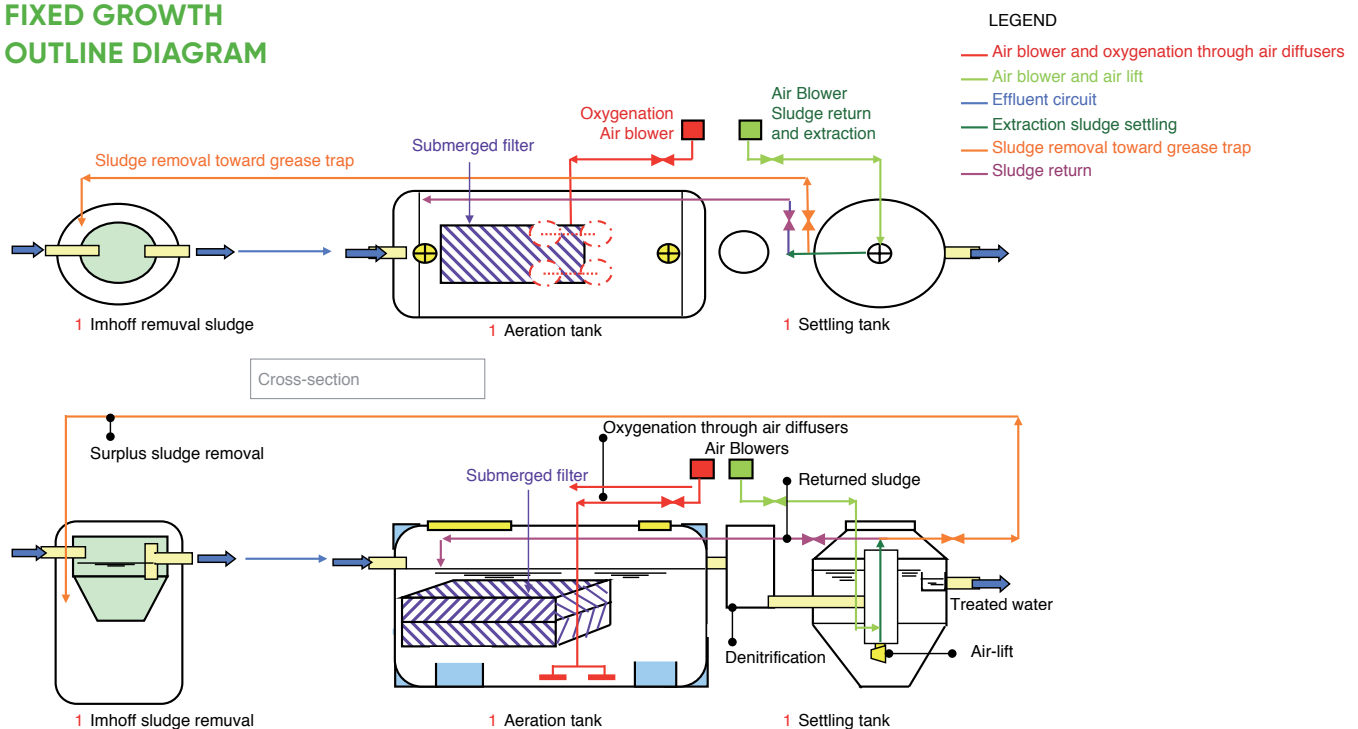

Effluents from agri-food industries

EFFLUENTS OF AGRI-FOOD INDUSTRIES

This sector is characterised by the effluents of predominant organic features. In consequence, plants using the activated sludge system process are recommended, since their treatment efficacy is higher than with the industrial wastewater.

However, in this case the industrial seasonal activities, or the ones with high flexibility of loading, the activated sludge with low loading are do not well adapt to these characteristics. Thus, ISEA has developed a process based on methanisation.

PROCESS OF METHANISATION

The methanisation is a procedure of natural, biological purification of the effluents based on a principle of decomposition of the organic compound inside the hydrocarbon deposits or bogs.

This process occurs with no presence of the air in the reactors, closed and with low congestion.

A specialised bacteria reproduce naturally in the reactors using the organic matter for their energetic and reproduction needs.

Carbon (C) and Hydrogen (H) - main components of the organic pollutant matter CHON transform

in gases rich in methane CH₄ (75 – 80 %) highly energetic. On the other hand, comparing to the biological aerobic processes within the activated sludge, the production of excess sludge is significantly reduced.

UASB INDUSTRIAL WASTEWATER TREATMENT PROCESS

Among the procedures currently proposed, the UASB (Upflow Aerobic Sludge Blanket) represents the biggest interest worldwide (65% market share). This system fully applies when the granulated anaerobic sludge is used, which allows to obtain a greater concentration of filter media and, consequently, a bigger volumetric loading. Moreover, the UASB procedure allows the sewage methanisation under a temperature range (20° till 40° C) thus, it can satisfy a large number of industries. The biological treatment through methanisation is generally used for industries, (breweries, stationery, chemical industries).

The new ISEA concept enables the methanisation system to be used also by activities like (canneries, wineries, distilleries, confectioneries.) who struggle to reconcile environmental requirements with economic profit.

METHANISATION DIAGRAM

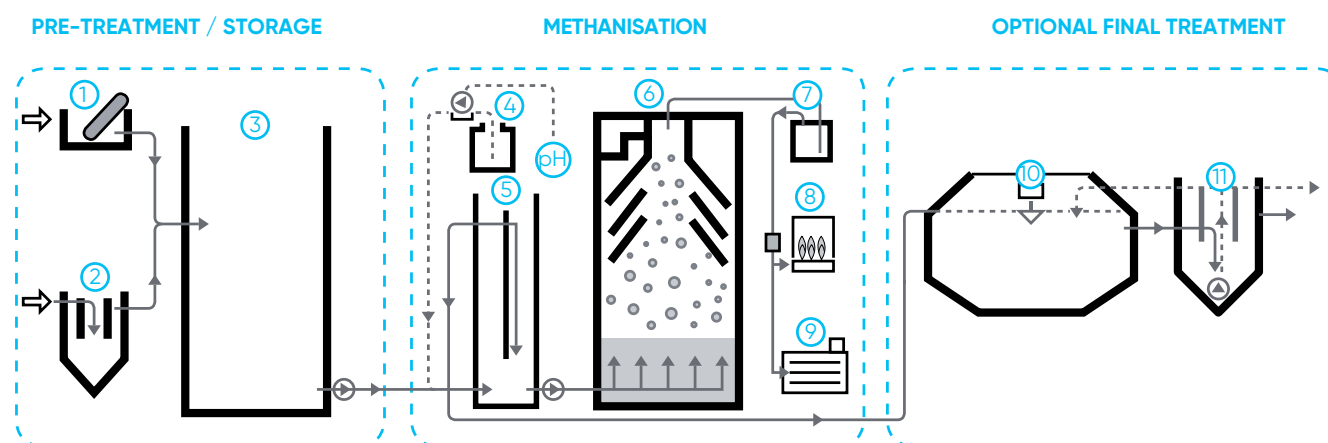

- (1) Screen
- (2) Settling chamber
- (3) Storage buffer

- (4) pH Correction
- (5) Recirculation
- (6) Methanizer
- (7) Gas Collector
- (8) Flare
- (9) Boiler

- (10) Aeration chamber
- (11) Filter

Effluents from chemical and mechanical companies

EFFLUENTS OF CHEMICAL AND MECHANICAL INDUSTRIES

For some of industrial discharges, the superiority of mineral materials over the organic ones causes that the treatment based on activated sludge is no longer suitable or it needs to be reinforced by a physico-chemical treatments.

A preliminary feasibility study conducted by ISEA, based on data communicated by the client, helps

to sketch a concept of the process and choose a convenient investment placement for optimal purification results.

This new concepts enable small and medium enterprises (SME), concerned about wastewater issue, to implement rapidly a low cost solution tailored for their needs and activity.

PROCESS MOST FREQUENTLY USED:

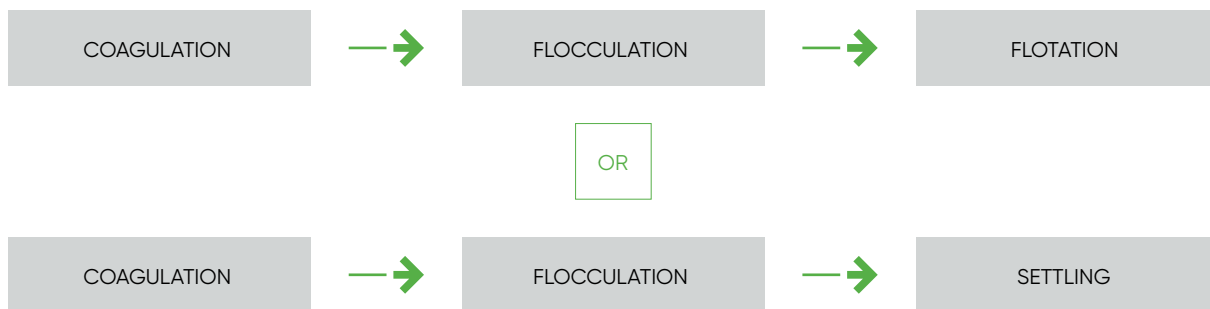

PROCESS THAT WE USE MOST FREQUENTLY:

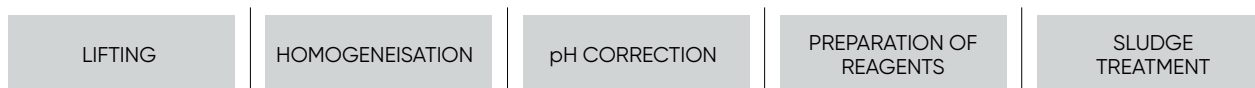

TO OBTAIN THIS, ISEA:

- performs a study
- design the treatment process
- produce the materials
- Install the system
- Provide information

STANDARD UNIT

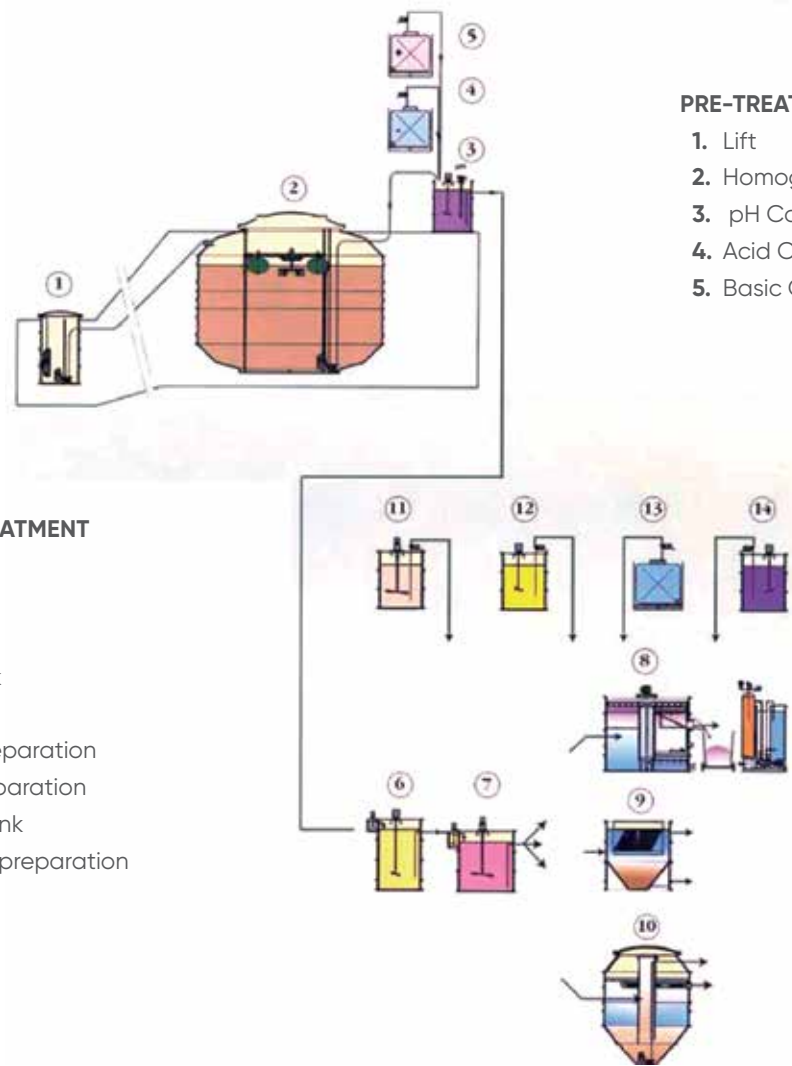

PRE-TREATMENT

1. Lift
2. Homogenization
3. pH Correction
4. Acid Chamber
5. Basic Chamber

PHYSICO-CHEMICAL TREATMENT

6. Coagulation
7. Flocculation
8. Aeroflotation
9. Lamellar settling tank
10. Static settling tank
11. Organic reagents preparation
12. Diluted reagents preparation
13. Reversible storage tank
14. Pulverulent reagents preparation

COMPACT UNIT

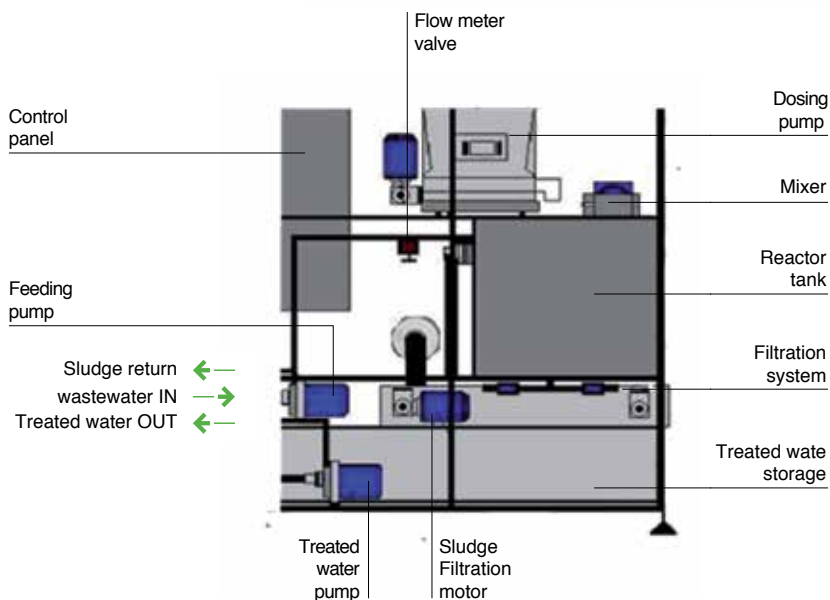

EFFICIENCY AND WARRANTIES

ISEA warrants that effluent quality meets the standards indicated in the European Directive 91/271/CE.

ISEA covers all electromechanical equipment with a 12-month warranty from the date of delivery.

ECOWASH



TREATMENT STAGES

Biofiltration technology is known both in theoretical operating mechanisms and in actual applications. Indeed, although there has been less research into biofiltration compared to activated sludge technology, many scientific articles have recently covered the cleaning action of attached biomasses, especially in reducing nitrogen content. Biofilters, biodiscs, percolating filters etc. are all engineering applications that have been known to people in the industry for some time and are all based on the biofiltration principle.

As a matter of fact, they all use micro-organisms. Contrary to activated sludge systems, though, instead of floating in the treatment system's aerated water (mixed liquor), these micro-organisms remain attached in one spot, i.e. clinging securely to media made up of honeycomb structures or plastic beads, gravel, mollusc shells etc. The advantages of these applications lie in the greater resistance of the biomass (micro-organisms), in the "solid" phase, to toxic agents, heat shock, and poor or discontinuous feeding, as well as in the lower energy consumption required for the associated aeration. They are particularly suitable when dealing with surfactants and nitrogen.

This is why we have come up with a technological solution that takes the adsorbing power of activated carbon, namely its ability to purify, and teamed it with the adsorbing, self-cleaning ability of micro-organisms. The result is a biological biofiltration wastewater treatment system called ECOWASH in which the bacterial decontaminating action is supplemented by the chemical and adsorbing action of the activated carbon. The system stands out from other wastewater biofilters precisely because the medium on which the bacteria develop is entirely made up of special activated carbon.

The treatment process stages can be summed up as follows:

1. Grit separation
2. Oil separation
3. Biofiltration

Grit separation

The water to be treated first passes through a grit separator in which primary separation of heavier materials, such as grit, silt and sludge, takes place by means of a settling process: they settle on the bottom of the tank and are removed at regular intervals.

Oil separation

The next step consists in using a gravity oil trap in which the lighter contaminating particles – essentially comprising hydrocarbons and a percentage of soaps – are separated as they remain in suspension.

Biofiltration

The last stage in the treatment process consists in sending water through the BIO-OXIDATION UNIT in which bacteria on the surface manage to oxidize and hence neutralize the contaminants in the wastewater by using the oxygen in the air. The water to be treated travels down through the percolating bed contained in the ECOWASH system, while low- pressure compressed air is blown upwards by a special blower in the opposite direction to the flow of water. A biological film forms on the surface of the filling media – kept active by the oxygen blown through it – and is responsible for breaking down contaminants in the wastewater.

Activated carbon is used as a filling medium in the ECOWASH system for the biological breakdown process and also as a way to exploit the chemical/ physical adsorption properties of the micropollutants (surfactants). The “clean” water leaving the system can be sent to the drain line leading to the public sewer. An equalization/homogenization station can be positioned as an optional extra upstream from the biological treatment system to provide a constant flow of influent, thus absorbing possible surges. As a result, performance is improved and, at the same time, it helps avoid problems in the system.

BLOCK DIAGRAM

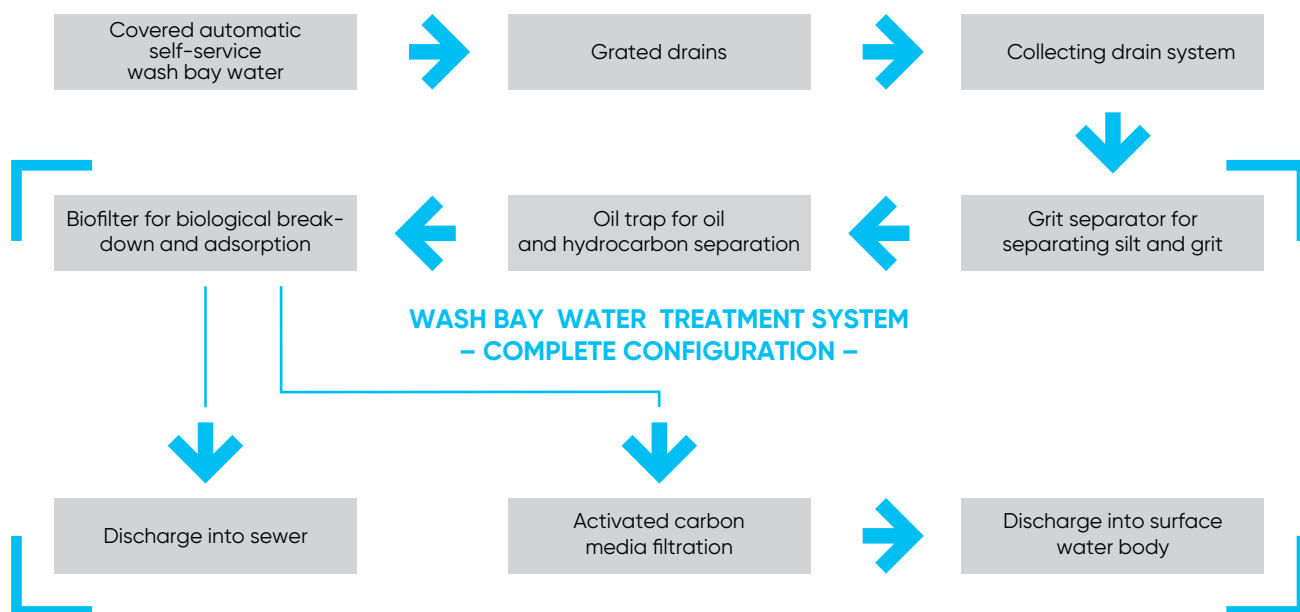

ECOWASH

Biofiltration system

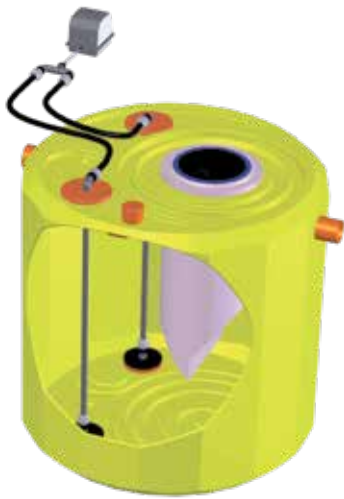

PRODUCT CATEGORY

Biofiltration system

PRODUCT NAME

ECOWASH

APPLICATION

CAR WASH

CAPACITY

1,5-5 m³/h

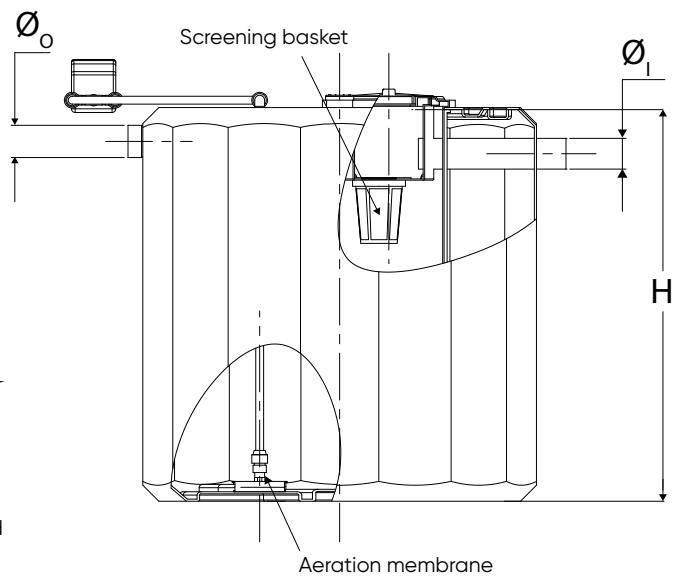
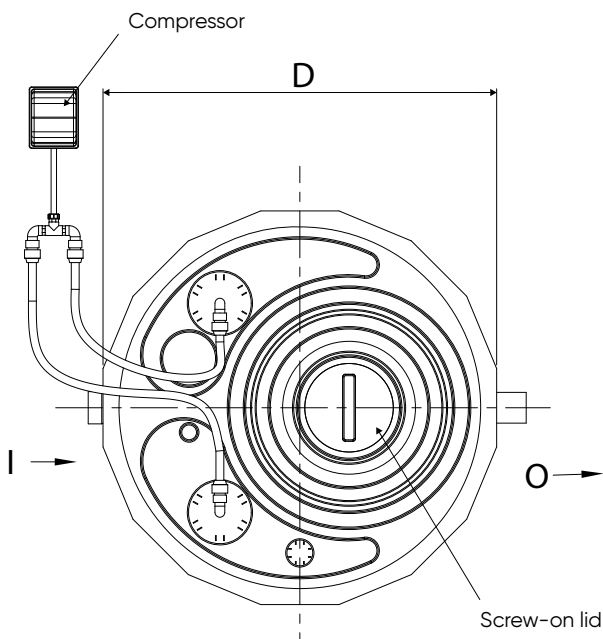

Item	Code	Bays	Maximum flow rate m ³ /h	D (cm)	H (cm)	Ø _i (cm)	Ø _u (cm)	Output (W)	Voltage (V)
ECOWASH1	0850	5	1,5	160	160	125	125	100	220
ECOWASH2	0851	10	3	160	200	140	140	150	220
ECOWASH3	0852	15	5	160	240	160	160	200	220

PRODUCT DESCRIPTION

Biofiltration is a BIO-OXIDATION unit in which bacteria on the surface manage to oxidize and hence neutralize the contaminants in the wastewater by using the oxygen in the air. The water to be treated travels down through the percolating bed contained in the Ecowash system, while low-pressure compressed air is blown upwards by a special blower in the opposite direction to the flow of water. A biological film forms on the surface of the filling media (kept active by the oxygen blown through it) and is responsible for breaking down contaminants in the wastewater.

Activated carbon is used as a filling medium in the Ecowash system for the biological breakdown process and as a way to exploit the chemical/physical absorption properties of the micro pollutants (surfactants).

The "clean" water leaving the system can be sent to the drain line leading to the public sewer.

INSTALLATION (p. 72)

PIT

Dig a suitably sized pit. Line the bottom of the pit with a 10 cm thick layer of sand or other aggregate with a particle size ranging from 0 to 5 mm. Dampen the sand.

CONNECTIONS

Connect the outlet to an inspection chamber with a PVC pipe.

Connect the waste water pipes to the Ecowash inlet in order to start the treatment process.

FILLING

Fill the Ecowash with clean water to start the separation process properly.

BACKFILLING AND FINISHING

Backfill around the sides with damp sand or other aggregate with a particle size ranging from 0 to 5 mm. In case of vehicular traffic, top the backfill with a 5 cm thick cement layer or 25 cm thick reinforced concrete layer.

USE

CHECKING AND MAINTENANCE

Make sure that the installation is carried out as prescribed in a professional manner. Regularly open the top fitted screwed covers in order to make sure that no coarse matter is blocking the wastewater inlet or treated water outlet. Regularly open the lateral screwed cover to verify that the carbon flakes are in the correct position that is at the bottom of the tank.

COMPLIANCE WITH STANDARD

91/271 CE

ECOWASH COMPLETE CONFIGURATION

Biofiltration system



PRODUCT CATEGORY

Biofiltration system

PRODUCT NAME

ECOWASH Complete Configuration

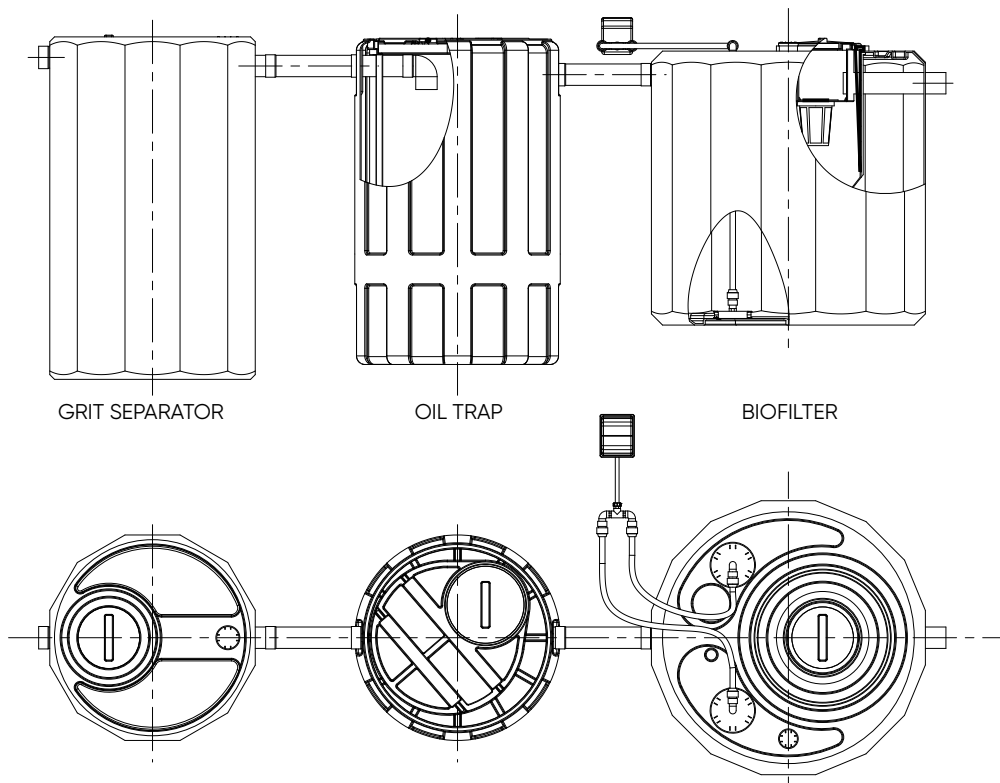

Item	Code	Bays	Maximum flow rate m ³ /h	Grit separator type	Oil trap HT type	Ecowash biofilter	Output (w)
ECOWASH1 C	0860	5	1,5	2000	2000	ECOWASH1	100
ECOWASH2 C	0861	10	3	3000	3000	ECOWASH2	150
ECOWASH3 C	0862	15	5	5000	5000	ECOWASH3	200

PRODUCT DESCRIPTION

The Ecowash Complete Configuration consists of:
GRIT separation;
OIL separation;
BIOFILTRATION.

Grit separation

The water to be treated first passes through a grit separator in which primary separation of heavier materials such as grit, silt and sludge, takes place by means of a settling process: they settle on the bottom of the tank and are removed at regular intervals.

Oil separation

The next step consists in using a gravity oil trap in which the lighter contaminating particles – essentially composing hydrocarbons and a percentage of soaps – are separated as they remain in suspension.

Biofiltration

is a BIO-OXIDATION unit in which bacteria on the surface manage to oxidize and hence neutralize the contaminants in the wastewater by using the oxygen in the air. The water to be treated travels down through the percolating bed contained in the Ecowash system, while low-pressure compressed air is blown upwards by a special blower in the opposite direction to the flow of water.

A biological film forms on the surface of the filling media (kept active by the oxygen blown through it) and is responsible for breaking down contaminants in the wastewater.

Activated carbon is used as a filling medium in the Ecowash system for the biological breakdown process and as a way to exploit the chemical/physical absorption properties of the micro pollutants (surfactants). The "clean" water leaving the system can be sent to the drain line leading to the public sewer.

INSTALLATION

PIT

Dig a suitably sized pit. Line the bottom of the pit with a 10 cm thick layer of sand or other aggregate with a particle size ranging from 0 to 5 mm. Dampen the sand.

CONNECTIONS Connect the wastewater pipes to the grit separator inlet, the grit separator outlet to the oil separator inlet, the oil separator outlet to the biofiltration inlet to start the treatment process.

FILLING

Level the surface on which the Ecowash complete configuration will sit, lower the units inside the pit and fill them with water.

BACFILLING and FINISHING

Backfill around the sides with damp sand or other aggregate with a particle size ranging from 0 to 5 mm. Top the backfill as described in the "underground installation procedure".

USE

Checking and Maintenance

Make sure that the installation is carried out as prescribed in a professional manner. Check at regular intervals to make sure no coarse matter is blocking the wastewater inlet or treated water outlet through the openings in the top fitted with screw-on covers.

Grit separator

At regular intervals, open the screw on cover to make sure that settled sand is not blocking the outlet pipe. Remove regularly the settled solids by using a vacuum clean company.

Oil separator

At regular intervals check that the oils, hydrocarbons and floating material have not filled completely the central chamber. Remove regularly these materials by using a vacuum-clean company.

Biofiltration

At regular intervals, open the screw-on lateral cover to verify that the carbon flakes are correctly on the bottom of the tank. Periodically open the screw-on central cover to verify the eventual presence of surfactants in settling tank.

COMPLIANCE WITH STANDARD

91/271 CE



Roto ISEA S.r.l.
Via Statale Emilia 34
26862 Guardamiglio
Lodi, Italy
tecnico@roto-isea.it
+ 39 0377 51881

www.roto-ISEA.it